

**State of Nebraska State Purchasing Bureau  
REQUEST FOR PROPOSAL FOR CONTRACTUAL  
SERVICES**

**RETURN TO:**

Name: State Purchasing Bureau  
Address: 1526 K Street, Suite  
130  
City/State/Zip: Lincoln, NE  
68508  
Phone:402-471-6500

<b>SOLICITATION NUMBER</b>	<b>RELEASE DATE</b>
RFP 5820 Z1	March 30, 2018
<b>OPENING DATE AND TIME</b>	<b>PROCUREMENT CONTACT</b>
May 31, 2018 2:00 p.m. Central Time	Nancy Storant/Dianna Gilliland

**PLEASE READ CAREFULLY!  
SCOPE OF SERVICE**

The State of Nebraska (State), Department of Administrative Services (DAS), Materiel Division, State Purchasing Bureau (SPB), is issuing this Request for Proposal (RFP) Number 5820 Z1 for the purpose of selecting a qualified Bidder to provide Network Management Control System. A more detailed description can be found in Section VI. The resulting contract may not be an exclusive contract as the State reserves the right to contract for the same or similar services from other sources now or in the future.

The term of the contract will be five (5) years commencing upon execution of the contract by the State and the Bidder (Parties)/notice to proceed. The Contract includes the option to renew for five (5) additional one (1) year renewal periods upon mutual agreement of the Parties. The State reserves the right to extend the period of this contract beyond the termination date when mutually agreeable to the Parties.

ALL INFORMATION PERTINENT TO THIS REQUEST FOR PROPOSAL CAN BE FOUND ON THE INTERNET AT:  
<http://das.nebraska.gov/materiel/purchasing.html>.

A mandatory Pre-Proposal Conference will be held on Thursday, April 19, 2018 at 8:30am CDT at the Terry Carpenter Building of Nebraska Educational Telecommunications located at 1800 N. 33<sup>rd</sup> Street Lincoln, Nebraska 68503.

**IMPORTANT NOTICE:** Pursuant to Neb. Rev. Stat. § 84-602.02, State contracts in effect as of January 1, 2014, and contracts entered into thereafter, must be posted to a public website. The resulting contract, the RFP, and the successful bidder's proposal or response will be posted to a public website managed by DAS, which can be found at <http://statecontracts.nebraska.gov>.

In addition and in furtherance of the State's public records Statute (Neb. Rev. Stat. § 84-712 et seq.), all proposals or responses received regarding this RFP will be posted to the State Purchasing Bureau public website.

**These postings will include the entire proposal or response. Bidders must request that proprietary information be excluded from the posting. The bidder must identify the proprietary information, mark the proprietary information according to state law, and submit the proprietary information in a separate container or envelope marked conspicuously in black ink with the words "PROPRIETARY INFORMATION". The bidder must submit a detailed written document showing that the release of the proprietary information would give a business advantage to named business competitor(s) and explain how the named business competitor(s) will gain an actual business advantage by disclosure of information. The mere assertion that information is proprietary or that a speculative business advantage might be gained is not sufficient. (See Attorney General Opinion No. 92068, April 27, 1992) THE BIDDER MAY NOT ASSERT THAT THE ENTIRE PROPOSAL IS PROPRIETARY. COST PROPOSALS WILL NOT BE CONSIDERED PROPRIETARY AND ARE A PUBLIC RECORD IN THE STATE OF NEBRASKA. The State will then determine, in its discretion, if the interests served by nondisclosure outweighs any public purpose served by disclosure. (See Neb. Rev. Stat. § 84-712.05(3)) The Bidder will be notified of the agency's decision. Absent a State determination that information is proprietary, the State will consider all information a public record subject to release regardless of any assertion that the information is proprietary.**

If the agency determines it is required to release proprietary information, the bidder will be informed. It will be the bidder's responsibility to defend the bidder's asserted interest in non-disclosure.

To facilitate such public postings, with the exception of proprietary information, the State of Nebraska reserves a royalty-free, nonexclusive, and irrevocable right to copy, reproduce, publish, post to a website, or otherwise use any contract, proposal, or response to this RFP for any purpose, and to authorize others to use the documents. Any individual or entity awarded a contract, or who submits a proposal or response to this RFP, specifically waives any copyright or other protection the contract, proposal, or response to the RFP may have; and, acknowledges that they have the ability and authority to enter into such waiver. This reservation and waiver is a prerequisite for submitting

a proposal or response to this RFP, and award of a contract. Failure to agree to the reservation and waiver will result in the proposal or response to the RFP being found non-responsive and rejected.

Any entity awarded a contract or submitting a proposal or response to the RFP agrees not to sue, file a claim, or make a demand of any kind, and will indemnify and hold harmless the State and its employees, volunteers, agents, and its elected and appointed officials from and against any and all claims, liens, demands, damages, liability, actions, causes of action, losses, judgments, costs, and expenses of every nature, including investigation costs and expenses, settlement costs, and attorney fees and expenses, sustained or asserted against the State, arising out of, resulting from, or attributable to the posting of the contract or the proposals and responses to the RFP, awards, and other documents.

# TABLE OF CONTENTS

REQUEST FOR PROPOSAL FOR CONTRACTUAL SERVICES .....	i
TABLE OF CONTENTS .....	iii
GLOSSARY OF TERMS .....	v
<b>I. PROCUREMENT PROCEDURE.....</b>	<b>1</b>
A. GENERAL INFORMATION .....	1
B. PROCURING OFFICE AND COMMUNICATION WITH STATE STAFF AND EVALUATORS .....	1
C. SCHEDULE OF EVENTS .....	2
D. WRITTEN QUESTIONS AND ANSWERS .....	3
E. PRE-PROPOSAL CONFERENCE .....	3
E. NOTICE OF INTENT TO ATTEND MANDATORY PRE-PROPOSAL CONFERENCE.....	3
F. RECYCLING (§81-15,159(d)(2)) .....	3
G. PRICES.....	3
H. SECRETARY OF STATE/TAX COMMISSIONER REGISTRATION REQUIREMENTS (Statutory) .....	3
I. ETHICS IN PUBLIC CONTRACTING .....	3
J. DEVIATIONS FROM THE REQUEST FOR PROPOSAL .....	4
K. SUBMISSION OF PROPOSALS.....	4
L. BID PREPARATION COSTS .....	4
M. FAILURE TO COMPLY WITH REQUEST FOR PROPOSAL .....	4
N. BID CORRECTIONS.....	5
O. LATE PROPOSALS .....	5
P. PROPOSAL OPENING .....	5
Q. REQUEST FOR PROPOSAL/PROPOSAL REQUIREMENTS .....	5
R. EVALUATION COMMITTEE .....	5
S. EVALUATION OF PROPOSALS .....	5
T. ORAL INTERVIEWS/PRESENTATIONS AND/OR DEMONSTRATIONS .....	6
U. BEST AND FINAL OFFER .....	6
V. REFERENCE AND CREDIT CHECKS .....	7
W. AWARD.....	7
<b>II. TERMS AND CONDITIONS.....</b>	<b>8</b>
F. GENERAL .....	8
B. NOTIFICATION .....	9
C. GOVERNING LAW (Statutory).....	9
D. BEGINNING OF WORK.....	9
E. CHANGE ORDERS.....	10
F. NOTICE OF POTENTIAL CONTRACTOR BREACH.....	10
G. BREACH .....	10
H. NON-WAIVER OF BREACH .....	11
I. SEVERABILITY .....	11
J. INDEMNIFICATION .....	11
K. ATTORNEY'S FEES .....	12
L. RETAINAGE .....	12
M. ASSIGNMENT, SALE, OR MERGER .....	13
N. CONTRACTING WITH OTHER NEBRASKA POLITICAL SUB-DIVISIONS .....	13
O. FORCE MAJEURE.....	13
P. CONFIDENTIALITY .....	14
Q. EARLY TERMINATION.....	14
R. CONTRACT CLOSEOUT.....	15
<b>III. CONTRACTOR DUTIES.....</b>	<b>16</b>
A. INDEPENDENT CONTRACTOR / OBLIGATIONS .....	16
B. EMPLOYEE WORK ELIGIBILITY STATUS .....	17
C. COMPLIANCE WITH CIVIL RIGHTS LAWS AND EQUAL OPPORTUNITY EMPLOYMENT / NONDISCRIMINATION (Statutory) .....	17

D.	COOPERATION WITH OTHER CONTRACTORS.....	17
E.	PERMITS, REGULATIONS, LAWS.....	18
F.	OWNERSHIP OF INFORMATION AND DATA / DELIVERABLES .....	18
G.	INSURANCE REQUIREMENTS .....	18
H.	ANTITRUST .....	21
I.	CONFLICT OF INTEREST.....	21
J.	STATE PROPERTY .....	22
K.	SITE RULES AND REGULATIONS .....	22
L.	ADVERTISING .....	22
M.	NEBRASKA TECHNOLOGY ACCESS STANDARDS (Statutory) .....	22
N.	DISASTER RECOVERY/BACK UP PLAN .....	23
O.	DRUG POLICY .....	23
<b>IV.</b>	<b>PAYMENT.....</b>	<b>24</b>
A.	PROHIBITION AGAINST ADVANCE PAYMENT (Statutory) .....	24
B.	TAXES (Statutory).....	24
B.	INVOICES .....	24
C.	INSPECTION AND APPROVAL .....	24
D.	PAYMENT .....	24
E.	LATE PAYMENT (Statutory) .....	25
F.	SUBJECT TO FUNDING / FUNDING OUT CLAUSE FOR LOSS OF APPROPRIATIONS.....	25
G.	RIGHT TO AUDIT (First Paragraph is Statutory) .....	25
<b>V.</b>	<b>PROJECT DESCRIPTION AND SCOPE OF WORK.....</b>	<b>26</b>
A.	PROJECT OVERVIEW .....	26
B.	SCOPE OF WORK.....	26
C.	CURRENT PROJECT ENVIRONMENT.....	26
D.	PROJECT REQUIREMENTS.....	33
E.	BUSINESS REQUIREMENTS .....	34
F.	TECHNICAL REQUIREMENTS .....	35
<b>VI.</b>	<b>PROJECT PLANNING AND MANAGEMENT .....</b>	<b>47</b>
A.	EVALUATE CURRENT PROJECT ENVIRONMENT .....	47
B.	POST IMPLEMENTATION SUPPORT .....	47
C.	DELIVERABLES .....	47
<b>VII.</b>	<b>PROPOSAL INSTRUCTIONS.....</b>	<b>49</b>
A.	PROPOSAL SUBMISSION .....	49
<b>VIII.</b>	<b>COST PROPOSAL REQUIREMENTS.....</b>	<b>52</b>
A.	COST SHEET .....	52
B.	PRICES.....	52
	<b>Form A Bidder Contact Sheet.....</b>	<b>53</b>
	<b>Form B Notification of Intent to Attend Pre-Proposal Conference.....</b>	<b>54</b>
	<b>REQUEST FOR PROPOSAL FOR CONTRACTUAL SERVICES FORM .....</b>	<b>55</b>

## GLOSSARY OF TERMS

**Acceptance Test Procedure:** Benchmarks and other performance criteria, developed by the State of Nebraska or other sources of testing standards, for measuring the effectiveness of products or services and the means used for testing such performance.

**Addendum:** Something to be added or deleted to an existing document; a supplement.

**After Receipt of Order (ARO):** After Receipt of Order

**Agency:** Any state agency, board, or commission other than the University of Nebraska, the Nebraska State colleges, the courts, the Legislature, or any other office or agency established by the Constitution of Nebraska.

**Agent/Representative:** A person authorized to act on behalf of another.

**Agnostic:** Denoting or relating to hardware or software that is compatible with many types of platforms or operating systems.

**Amend:** To alter or change by adding, subtracting, or substituting.

**Amendment:** A written correction or alteration to a document.

**Appropriation:** Legislative authorization to expend public funds for a specific purpose. Money set apart for a specific use.

**API:** Application Programming Interface

**Award:** All purchases, leases, or contracts which are based on competitive proposals will be awarded according to the provisions in the RFP. The State reserves the right to reject any or all proposals, wholly or in part, or to award to multiple bidders in whole or in part. The State reserves the right to waive any deviations or errors that are not material, do not invalidate the legitimacy of the proposal, and do not improve the bidder's competitive position. All awards will be made in a manner deemed in the best interest of the State.

**Best and Final Offer (BAFO):** In a competitive bid, the final offer submitted which contains the bidder's (vendor's) most favorable terms for price.

**Bid/Proposal:** The offer submitted by a vendor in a response to a written solicitation.

**Bid Bond:** An insurance agreement, accompanied by a monetary commitment, by which a third party (the surety) accepts liability and guarantees that the vendor will not withdraw the bid.

**Bidder:** A vendor who submits an offer bid in response to a written solicitation.

**Business:** Any corporation, partnership, individual, sole proprietorship, joint-stock company, joint venture, or any other private legal entity.

**Business Day:** Any weekday, except State-recognized holidays.

**Calendar Day:** Every day shown on the calendar including Saturdays, Sundays, and State/Federal holidays.

**Cancellation:** To call off or revoke a purchase order without expectation of conducting or performing it at a later time.

**Central Processing Unit (CPU):** Any computer or computer system that is used by the State to store, process, or retrieve data or perform other functions using Operating Systems and applications software.

**Change Order:** Document that provides amendments to an executed purchase order or contract.

**Collusion:** An agreement or cooperation between two or more persons or entities to accomplish a fraudulent, deceitful, or unlawful purpose.

**Commodities:** Any equipment, material, supply or goods; anything movable or tangible that is provided or sold.

**Commodities Description:** Detailed descriptions of the items to be purchased; may include information necessary to obtain the desired quality, type, color, size, shape, or special characteristics necessary to perform the work intended to produce the desired results.

**Competition:** The effort or action of two or more commercial interests to obtain the same business from third parties.

**Confidential Information:** Unless otherwise defined below, "Confidential Information" shall also mean proprietary trade secrets, academic and scientific research work which is in progress and unpublished, and other information which if released would give advantage to business competitors and serve no public purpose (see Neb. Rev. Stat. §84-712.05(3)). In accordance with Nebraska Attorney General Opinions 92068 and 97033, proof that information is proprietary requires identification of specific, named competitor(s) who would be advantaged by release of the information and the specific advantage the competitor(s) would receive.

**Contract:** An agreement between two or more parties creating obligations that are enforceable or otherwise recognizable at law; the writing that sets forth such an agreement.

**Contract Administration:** The management of the contract which includes and is not limited to; contract signing, contract amendments and any necessary legal actions.

**Contract Award:** Occurs upon execution of the State document titled "Service Contract Award" by the proper authority.

**Contract Management:** The management of day to day activities at the agency which includes and is not limited to ensuring deliverables are received, specifications are met, handling meetings and making payments to the Contractor.

**Contract Period:** The duration of the contract.

**Contractor:** Any individual or entity having a contract to furnish commodities or services.

**Control:** The ability to issue all available commands in order to operate or regulate the behavior of a particular device as designed by the manufacturer.

**Cooperative Purchasing:** The combining of requirements of two or more political entities to obtain advantages of volume purchases, reduction in administrative expenses or other public benefits.

**Copyright:** A property right in an original work of authorship fixed in any tangible medium of expression, giving the holder the exclusive right to reproduce, adapt and distribute the work.

**Critical Program Error:** Any Program Error, whether or not known to the State, which prohibits or significantly impairs use of the Licensed Software as set forth in the documentation and intended in the contract.

**Customer Service:** The process of ensuring customer satisfaction by providing assistance and advice on those products or services provided by the Contractor.

**Default:** The omission or failure to perform a contractual duty.

**Device:** Used to describe a thing made or adapted for a particular purpose, especially a piece of mechanical or electronic equipment. Synonymous with implement, gadget, utensil, tool, appliance, apparatus, instrument, machine, mechanism, contrivance, contraption, gizmo, widget, and doohickey.

**Deviation:** Any proposed change(s) or alteration(s) to either the terms and conditions or deliverables within the scope of the written solicitation or contract.

**Direct:** Used to describe a connection to a device rather than an intermediary device connected to the device.  
(Example: A KVM connection to a computer as opposed to a remote session.)

**Evaluation:** The process of examining an offer after opening to determine the vendor's responsibility, responsiveness to requirements, and to ascertain other characteristics of the offer that relate to determination of the successful award.

**Evaluation Committee:** Committee(s) appointed by the requesting agency that advises and assists the procuring office in the evaluation of bids/proposals (offers made in response to written solicitations).

**Extension:** Continuance of a contract for a specified duration upon the agreement of the parties beyond the original Contract Period. Not to be confused with "Renewal Period".

**Free on Board (F.O.B.) Destination:** The delivery charges are included in the quoted price and prepaid by the vendor. Vendor is responsible for all claims associated with damages during delivery of product.

**Free on Board (F.O.B.) Point of Origin:** The delivery charges are not included in the quoted price and are the responsibility of the agency. Agency is responsible for all claims associated with damages during delivery of product.

**Foreign Corporation:** A foreign corporation that was organized and chartered under the laws of another state, government, or country.

**Installation Date:** The date when the procedures described in "Installation by Contractor", and "Installation by State", as found in the RFP, or contract, are completed.

**Interested Party:** A person, acting in their personal capacity, or an entity entering into a contract or other agreement creating a legal interest therein.

**Late Bid/Proposal:** An offer received after the Opening Date and Time.

**Licensed Software Documentation:** The user manuals and any other materials in any form or medium customarily provided by the Contractor to the users of the Licensed Software which will provide the State with sufficient information to operate, diagnose, and maintain the Licensed Software properly, safely, and efficiently.

**Mandatory/Must:** Required, compulsory, or obligatory.

**May:** Discretionary, permitted; used to express possibility.

**Module (see System):** A collection of routines and data structures that perform a specific function of software.

**Monitor:** The act of using an instrument or device for observing, checking, or keeping a continuous record of the progress or quality of a process or processes over a period of time.

**Must:** See Mandatory/ Must and Shall/Will/Must.

**National Institute for Governmental Purchasing (NIGP):** National Institute of Governmental Purchasing – Source used for assignment of universal commodity codes to goods and services.

**Network Management Control System (NMCS):** A set of hardware and/or software tools that allow an IT or Engineering professional to supervise and control the individual components of a network within a larger network management framework.

**NMCS:** Network Management Control System.

**Open Market Purchase:** Authorization may be given to an agency to purchase items above direct purchase authority due to the unique nature, price, quantity, location of the using agency, or time limitations by the AS Materiel Division, State Purchasing Bureau.

**Opening Date and Time:** Specified date and time for the public opening of received, labeled, and sealed formal proposals.

**Operating System:** The control program in a computer that provides the interface to the computer hardware and peripheral devices, and the usage and allocation of memory resources, processor resources, input/output resources, and security resources.

**Outsourcing:** The contracting out of a business process which an organization may have previously performed internally or has a new need for, to an independent organization from which the process is purchased back.

**Payroll & Financial Center (PFC):** Electronic procurement system of record.

**Performance Bond:** An insurance agreement, accompanied by a monetary commitment, by which a third party (the surety) accepts liability and guarantees that the Contractor fulfills any and all obligations under the contract.

**Platform:** A specific hardware and Operating System combination that is different from other hardware and Operating System combinations to the extent that a different version of the Licensed Software product is required to execute properly in the environment established by such hardware and Operating System combination.

**Point of Contact (POC):** The person designated to receive communications and to communicate.

**Pre-Bid/Pre-Proposal Conference:** A meeting scheduled for the purpose of clarifying a written solicitation and related expectations.

**Product:** Something that is distributed commercially for use or consumption and that is usually (1) tangible personal property, (2) the result of fabrication or processing, and (3) an item that has passed through a chain of commercial distribution before ultimate use or consumption.

**Program Error:** Code in Licensed Software which produces unintended results or actions, or which produces results or actions other than those described in the specifications. A program error includes, without limitation, any Critical Program Error.

**Program Set:** The group of programs and products, including the Licensed Software specified in the RFP, plus any additional programs and products licensed by the State under the contract for use by the State.

**Project:** The total scheme, program, or method worked out for the accomplishment of an objective, including all documentation, commodities, and services to be provided under the contract.

**Proposal:** See Bid/Proposal.

**Proprietary Information:** Proprietary information is defined as trade secrets, academic and scientific research work which is in progress and unpublished, and other information which if released would give advantage to business competitors and serves no public purpose (see Neb. Rev. Stat. § 84-712.05(3)). In accordance with Attorney General Opinions 92068 and 97033, proof that information is proprietary requires identification of specific named competitor(s) advantaged by release of the information and the demonstrated advantage the named competitor(s) would gain by the release of information.

**Protest/Grievance:** A complaint about a governmental action or decision related to a RFP or resultant contract, brought by a vendor who has timely submitted a bid response in connection with the award in question, to AS Materiel Division or another designated agency with the intention of achieving a remedial result.

**Public Proposal Opening:** The process of opening correctly submitted offers at the time and place specified in the written solicitation and in the presence of anyone who wished to attend.

**Recommended Hardware Configuration:** The data processing hardware (including all terminals, auxiliary storage, communication, and other peripheral devices) to the extent utilized by the State as recommended by the Contractor.

**Release Date:** The date of public release of the written solicitation to seek offers.

**Renewal Period:** Optional contract periods subsequent to the original Contract Period for a specified duration with previously agreed to terms and conditions. Not to be confused with Extension.

**Request for Information (RFI):** A general invitation to vendors requesting information for a potential future solicitation. The RFI is typically used as a research and information gathering tool for preparation of a solicitation.

**Request for Proposal (RFP):** A written solicitation utilized for obtaining competitive offers.

**Responsible Bidder:** A bidder who has the capability in all respects to perform fully and lawfully all requirements with integrity and reliability to assure good faith performance.

**Responsive Bidder:** A bidder who has submitted a bid which conforms to all requirements of the solicitation document.

**Shall/Will/Must:** An order/command; mandatory.

**Should:** Expected; suggested, but not necessarily mandatory.

**Software License:** Legal instrument with or without printed material that governs the use or redistribution of licensed software.

**Sole Source – Commodity:** When an item is available from only one source due to the unique nature of the requirement, its supplier, or market conditions.

**Sole Source – Services:** A service of such a unique nature that the vendor selected is clearly and justifiably the only practical source to provide the service. Determination that the vendor selected is justifiably the sole source is based on either the uniqueness of the service or sole availability at the location required.

**Specifications:** The detailed statement, especially of the measurements, quality, materials, and functional characteristics, or other items to be provided under a contract.



**Statutory:** These clauses are controlled by state law and are not subject to negotiation.

**Subcontractor:** Individual or entity with whom the contractor enters a contract to perform a portion of the work awarded to the contractor.

**System (see Module):** Any collection or aggregation of two (2) or more Modules that is designed to function, or is represented by the Contractor as functioning or being capable of functioning, as an entity.

**Termination:** Occurs when either Party, pursuant to a power created by agreement or law, puts an end to the contract prior to the stated expiration date. All obligations which are still executory on both sides are discharged but any right based on prior breach or performance survives.

**Third Party:** Any person or entity, including but not limited to fiduciaries, shareholders, owners, officers, managers, employees, legally disinterested persons, and sub-contractors or agents, and their employees. It shall not include any entity or person who is an interested Party to the contract or agreement.

**Trade Secret:** Information, including, but not limited to, a drawing, formula, pattern, compilation, program, device, method, technique, code, or process that (a) derives independent economic value, actual or potential, from not being known to, and not being ascertainable by proper means by, other persons who can obtain economic value from its disclosure or use; and (b) is the subject of efforts that are reasonable under the circumstances to maintain its secrecy (see Neb. Rev. Stat. §87-502(4)).

**Trademark:** A word, phrase, logo, or other graphic symbol used by a manufacturer or vendor to distinguish its product from those of others, registered with the U.S. Patent and Trademark Office.

**Upgrade:** Any change that improves or alters the basic function of a product or service.

**Vendor:** An individual or entity lawfully conducting business in the State of Nebraska, or licensed to do so, who seeks to provide goods or services under the terms of a written solicitation.

**Vendor Performance Report:** A report issued to the Contractor by State Purchasing Bureau when products or services delivered or performed fail to meet the terms of the purchase order, contract, and/or specifications, as reported to State Purchasing Bureau by the agency. The State Purchasing Bureau shall contact the Contractor regarding any such report. The vendor performance report will become a part of the permanent record for the Contractor. The State may require vendor to cure. Two such reports may be cause for immediate termination.

**Will:** See Shall/Will/Must.

**Work Day:** See Business Day.

**I. PROCUREMENT PROCEDURE**

**A. GENERAL INFORMATION**

The RFP is designed to solicit proposals from qualified Bidders who will be responsible for providing Network Management Control System at a competitive and reasonable cost.

Proposals shall conform to all instructions, conditions, and requirements included in the RFP. Prospective bidders are expected to carefully examine all documents, schedules, and requirements in this RFP, and respond to each requirement in the format prescribed. Proposals may be found non-responsive if they do not conform to the RFP.

**B. PROCURING OFFICE AND COMMUNICATION WITH STATE STAFF AND EVALUATORS**

Procurement responsibilities related to this RFP reside with the State Purchasing Bureau. The point of contact (POC) for the procurement is as follows:

Name: Nancy Storant/Dianna Gilliland  
Agency: State Purchasing Bureau  
Address: 1526 K Street, Suite 130  
Lincoln, NE 68508  
Telephone: 402-471-6500  
  
E-Mail: as.materielpurchasing@nebraska.gov

From the date the RFP is issued until the Intent to Award is issued, communication from the Bidder is limited to the POC listed above. After the Intent to Award is issued, the Bidder may communicate with individuals the State has designated as responsible for negotiating the contract on behalf of the State. No member of the State Government, employee of the State, or member of the Evaluation Committee is empowered to make binding statements regarding this RFP. The POC will issue any clarifications or opinions regarding this RFP in writing. Only the buyer can modify the RFP, answer questions, render opinions, and only the SPB or awarding agency can award a contract. Bidders shall not have any communication with, or attempt to communicate or influence any evaluator involved in this RFP.

The following exceptions to these restrictions are permitted:

1. Contact made pursuant to pre-existing contracts or obligations;
2. Contact required by the schedule of events or an event scheduled later by the RFP POC; and
3. Contact required for negotiation and execution of the final contract.

*The State reserves the right to reject a bidder's proposal, withdraw an Intent to Award, or terminate a contract if the State determines there has been a violation of these procurement procedures.*



**D. WRITTEN QUESTIONS AND ANSWERS**

Questions regarding the meaning or interpretation of any RFP provision must be submitted in writing to the State Purchasing Bureau and clearly marked "RFP Number 5820 Z1; Network Management Control System Questions". The POC is not obligated to respond to questions that are received late per the Schedule of Events.

Bidders should present, as questions, any assumptions upon which the Bidder's proposal is or might be developed. Proposals will be evaluated without consideration of any known or unknown assumptions of a bidder. The contract will not incorporate any known or unknown assumptions of a bidder.

It is preferred that questions be sent via e-mail to [as.materielpurchasing@nebraska.gov](mailto:as.materielpurchasing@nebraska.gov), but may be delivered by hand or by U.S. Mail. It is recommended that Bidders submit questions using the following format.

RFP Reference	Section	RFP Number	Page	Question

Written answers will be posted at <http://das.nebraska.gov/materiel/purchasing.html> per the Schedule of Events.

**E. PRE-PROPOSAL CONFERENCE**

A pre-proposal conference will be held per the Schedule of Events. Attendance at the pre-proposal conference is mandatory in order to submit proposal. Bidders will have an opportunity to ask questions at the conference to assist in the clarification and understanding of the RFP requirements. Questions that have a material impact on the RFP or process, and questions that are relevant to all bidders, will be answered in writing and posted at <http://das.nebraska.gov/materiel/purchasing.html>. An answer must be posted to be binding on the State. The State will attempt to provide verbal answers to questions that do not impact the RFP or process, and are only of interest to an individual bidder during the conference. If a bidder feels it necessary to have a binding answer to a question that was answered verbally, the question should be submitted in writing per the Schedule of Events.

**E. NOTICE OF INTENT TO ATTEND MANDATORY PRE-PROPOSAL CONFERENCE**

Bidders should notify the POC of their intent to attend by submitting a "Notification of Intent to Attend the Pre-Proposal Conference Form" (see Form B) by hand-delivery, U.S. Mail, or email at [as.materielpurchasing@nebraska.gov](mailto:as.materielpurchasing@nebraska.gov)

**F. RECYCLING (§81-15,159(d)(2))**

Preference will be given to items which are manufactured or produced from recycled material or which can be readily reused or recycled after their normal use. Preference will also be given to purchases of corn-based biodegradable plastics and road deicers if available and suitable. No preference shall be given if such preference would result in the purchase of products, materials, or supplies that are of inadequate quality or of substantially higher cost.

**G. PRICES**

Prices submitted on the cost proposal form shall remain fixed for the first two years (2) of the contract. Any request for a price increase subsequent to the first two years (2) of the contract shall not exceed seven and one half percent (7.5 %) of the previous Contract period. Increases will be cumulative across the remaining periods of the contract. Requests for an increase must be submitted in writing to the State Purchasing Bureau a minimum of 120 days prior to the end of the current contract period. Documentation may be required by the State to support the price increase.

The State reserves the right to deny any requested price increase. No price increases are to be billed to any State Agencies prior to written amendment of the contract by the parties.

**H. SECRETARY OF STATE/TAX COMMISSIONER REGISTRATION REQUIREMENTS (Statutory)**

All bidders must be authorized to transact business in the State of Nebraska and comply with all Nebraska Secretary of State Registration requirements. The bidder who is the recipient of an Intent to Award will be required to certify that it has complied and produce a true and exact copy of its current (within ninety (90) calendar days of the intent to award) Certificate or Letter of Good Standing, or in the case of a sole proprietorship, provide written documentation of sole proprietorship and complete the United States Citizenship Attestation Form, available on the Department of Administrative Services website at <http://das.nebraska.gov/materiel/purchasing.html>. This must be accomplished prior to execution of the contract.

**I. ETHICS IN PUBLIC CONTRACTING**

The State reserves the right to reject bids, withdraw an intent to award or award, or terminate a contract if a bidder commits or has committed ethical violations, which include, but are not limited to:

1. Offering or giving, directly or indirectly, a bribe, fee, commission, compensation, gift, gratuity, or anything of value to any person or entity in an attempt to influence the bidding process;

2. Utilize the services of lobbyists, attorneys, political activists, or consultants to influence or subvert the bidding process;
3. Being considered for, presently being, or becoming debarred, suspended, ineligible, or excluded from contracting with any state or federal entity;
4. Submitting a proposal on behalf of another Party or entity; and
5. Collude with any person or entity to influence the bidding process, submit sham proposals, preclude bidding, fix pricing or costs, create an unfair advantage, subvert the bid, or prejudice the State.

The Bidder shall include this clause in any subcontract entered into for the exclusive purpose of performing this contract.

Bidder shall have an affirmative duty to report any violations of this clause by the Bidder throughout the bidding process, and throughout the term of this contract for the successful Bidder and their subcontractors.

**J. DEVIATIONS FROM THE REQUEST FOR PROPOSAL**

The requirements contained in the RFP become a part of the terms and conditions of the contract resulting from this RFP. Any deviations from the RFP in Sections II through VI must be clearly defined by the bidder in its proposal and, if accepted by the State, will become part of the contract. Any specifically defined deviations must not be in conflict with the basic nature of the RFP, requirements, or applicable state or federal laws or statutes. "Deviation", for the purposes of this RFP, means any proposed changes or alterations to either the contractual language or deliverables within the scope of this RFP. The State discourages deviations and reserves the right to reject proposed deviations.

**K. SUBMISSION OF PROPOSALS**

Bidders should submit one proposal marked on the first page: "ORIGINAL". If multiple proposals are submitted, the State will retain one copy marked "ORIGINAL" and destroy the other copies. The Bidder is solely responsible for any variance between the copies submitted. Proposal responses should include the completed Form A, "Bidder Contact Sheet". Proposals must reference the RFP number and be sent to the specified address. Please note that the address label should appear as specified in Section I B. on the face of each container or bidder's bid response packet. If a recipient phone number is required for delivery purposes, 402-471-6500 should be used. The RFP number should be included in all correspondence.

Emphasis should be concentrated on conformance to the RFP instructions, responsiveness to requirements, completeness, and clarity of content. If the bidder's proposal is presented in such a fashion that makes evaluation difficult or overly time consuming the State reserves the right to reject the proposal as non-conforming.

By signing the "Request for Proposal for Contractual Services" form, the bidder guarantees compliance with the provisions stated in this RFP.

The State shall not incur any liability for any costs incurred by bidders in replying to this RFP, in the demonstrations and/or oral presentations, or in any other activity related to bidding on this RFP.

The Technical and Cost Proposals should be packaged separately (loose-leaf binders are preferred) on standard 8 ½" by 11" paper, except that charts, diagrams and the like may be on fold-outs which, when folded, fit into the 8 ½" by 11" format. Pages may be consecutively numbered for the entire proposal, or may be numbered consecutively within sections. Figures and tables should be numbered and referenced in the text by that number. They should be placed as close as possible to the referencing text. The Technical Proposal should not contain any reference to dollar amounts. However, information such as data concerning labor hours and categories, materials, subcontracts and so forth, shall be considered in the Technical Proposal so that the bidder's understanding of the scope of work may be evaluated. The Technical Proposal shall disclose the bidder's technical approach in as much detail as possible, including, but not limited to, the information required by the Technical Proposal instructions.

**L. BID PREPARATION COSTS**

The State shall not incur any liability for any costs incurred by Bidders in replying to this RFP, including any activity related to bidding on this RFP.

**M. FAILURE TO COMPLY WITH REQUEST FOR PROPOSAL**

Violation of the terms and conditions contained in this RFP or any resultant contract, at any time before or after the award, shall be grounds for action by the State which may include, but is not limited to, the following:

1. Rejection of a bidder's proposal;
2. Withdrawal of the Intent to Award;
3. Withdrawal of the Award;
4. Termination of the resulting contract;
5. Legal action; and

6. Suspension of the bidder from further bidding with the State for the period of time relative to the seriousness of the violation, such period to be within the sole discretion of the State.

**N. BID CORRECTIONS**

A bidder may correct a mistake in a bid prior to the time of opening by giving written notice to the State of intent to withdraw the bid for modification or to withdraw the bid completely. Changes in a bid after opening are acceptable only if the change is made to correct a minor error that does not affect price, quantity, quality, delivery, or contractual conditions. In case of a mathematical error in extension of price, unit price shall govern.

**O. LATE PROPOSALS**

Proposals received after the time and date of the proposal opening will be considered late proposals. Late proposals will be returned unopened, if requested by the bidder and at bidder's expense. The State is not responsible for proposals that are late or lost regardless of cause or fault.

**P. PROPOSAL OPENING**

The opening of proposals will be public and the bidders will be announced. Proposals **WILL NOT** be available for viewing by those present at the proposal opening. Vendors may contact the State to schedule an appointment for viewing proposals after the Intent to Award has been posted to the website. Once proposals are opened, they become the property of the State of Nebraska and will not be returned.

**Q. REQUEST FOR PROPOSAL/PROPOSAL REQUIREMENTS**

The proposals will first be examined to determine if all requirements listed below have been addressed and whether further evaluation is warranted. Proposals not meeting the requirements may be rejected as non-responsive. The requirements are:

1. Original Request for Proposal for Contractual Services form signed using an indelible method;
2. Clarity and responsiveness of the proposal;
3. Completed Corporate Overview;
4. Completed Sections II through VI;
5. Completed Technical Approach; and
6. Completed State Cost Proposal Template.

**R. EVALUATION COMMITTEE**

Proposals are evaluated by members of an Evaluation Committee(s). The Evaluation Committee(s) will consist of individuals selected at the discretion of the State. Names of the members of the Evaluation Committee(s) will not be published prior to the intent to award.

Any contact, attempted contact, or attempt to influence an evaluator that is involved with this RFP may result in the rejection of this proposal and further administrative actions.

**S. EVALUATION OF PROPOSALS**

All proposals that are responsive to the RFP will be evaluated. Each evaluation category will have a maximum point potential. The State will conduct a fair, impartial, and comprehensive evaluation of all proposals in accordance with the criteria set forth below. Areas that will be addressed and scored during the evaluation include:

1. Corporate Overview should include but is not limited to:
  - a. the ability, capacity, and skill of the bidder to deliver and implement the system or project that meets the requirements of the RFP;
  - b. the character, integrity, reputation, judgment, experience, and efficiency of the bidder;
  - c. whether the bidder can perform the contract within the specified time frame;
  - d. the quality of bidder performance on prior contracts;
- a. such other information that may be secured and that has a bearing on the decision to award the contract;
2. Technical Approach;  
Understanding of the project requirements
  - b. Proposed development approach
  - c. Technical considerations
  - d. Detailed project work plan
- a. Deliverables and due dates
3. Cost Proposal

**Neb. Rev. Stat. §73-107 allows for a preference for a resident disabled veteran or business located in a designated enterprise zone.** When a state contract is to be awarded to the lowest responsible bidder, a resident disabled veteran or a business located in a designated enterprise zone under the Enterprise Zone Act shall be allowed a preference over any other resident or nonresident bidder, if all other factors are equal.

**Resident disabled veterans means any person (a) who resides in the State of Nebraska, who served in the United States Armed Forces, including any reserve component or the National Guard, who was discharged or otherwise separated with a characterization of honorable or general (under honorable conditions), and who possesses a disability rating letter issued by the United States Department of Veterans Affairs establishing a service-connected disability or a disability determination from the United States Department of Defense and (b)(i) who owns and controls a business or, in the case of a publicly owned business, more than fifty percent of the stock is owned by one or more persons described in subdivision (a) of this subsection and (ii) the management and daily business operations of the business are controlled by one or more persons described in subdivision(a) of this subsection. Any contract entered into without compliance with this section shall be null and void.**

Therefore, if a resident disabled veteran or business located in a designated enterprise zone submits a proposal in accordance with Neb. Rev. Stat. §73-107 and has so indicated on the RFP cover page under "Bidder must complete the following" requesting priority/preference to be considered in the award of this contract, the following will need to be submitted by the vendor within ten (10) business days of request:

1. Documentation from the United States Armed Forces confirming service;
4. Documentation of discharge or otherwise separated characterization of honorable or general (under honorable conditions);
5. Disability rating letter issued by the United States Department of Veterans Affairs establishing a service-connected disability or a disability determination from the United States Department of Defense; and
6. Documentation which shows ownership and control of a business or, in the case of a publicly owned business, more than fifty percent of the stock is owned by one or more persons described in subdivision (a) of this subsection; and the management and daily business operations of the business are controlled by one or more persons described in subdivision (a) of this subsection.

Failure to submit the requested documentation within ten (10) business days of notice will disqualify the bidder from consideration of the preference.

#### **T. ORAL INTERVIEWS/PRESENTATIONS AND/OR DEMONSTRATIONS**

The State may determine after the completion of the Technical and Cost Proposal evaluation that oral interviews/presentations and/or demonstrations are required. Every bidder may not be given an opportunity to interview/present and/or give demonstrations; the State reserves the right, in its discretion, to select only the top scoring bidders to present/give oral interviews. The scores from the oral interviews/presentations and/or demonstrations will be added to the scores from the Technical and Cost Proposals. The presentation process will allow the bidders to demonstrate their proposal offering, explaining and/or clarifying any unusual or significant elements related to their proposals. Bidders' key personnel, identified in their proposal, may be requested to participate in a structured interview to determine their understanding of the requirements of this proposal, their authority and reporting relationships within their firm, and their management style and philosophy. Only representatives of the State and the presenting bidder will be permitted to attend the oral interviews/presentations and/or demonstrations. A written copy or summary of the presentation, and demonstrative information (such as briefing charts, et cetera) may be offered by the bidder, but the State reserves the right to refuse or not consider the offered materials. Bidders shall not be allowed to alter or amend their proposals.

Once the oral interviews/presentations and/or demonstrations have been completed, the State reserves the right to make an award without any further discussion with the bidders regarding the proposals received.

Any cost incidental to the oral interviews/presentations and/or demonstrations shall be borne entirely by the bidder and will not be compensated by the State.

#### **U. BEST AND FINAL OFFER**

If best and final offers (BAFO) are requested by the State and submitted by the bidder, they will be evaluated (using the stated BAFO criteria), scored, and ranked by the Evaluation Committee. The State reserves the right to conduct more than one Best and Final Offer. The award will then be granted to the highest scoring bidder. However, a bidder should provide its best offer in its original proposal. Bidders should not expect that the State will request a best and final offer.

**V. REFERENCE AND CREDIT CHECKS**

The State reserves the right to conduct and consider reference and credit checks. The State reserves the right to use third parties to conduct reference and credit checks. By submitting a proposal in response to this RFP, the bidder grants to the State the right to contact or arrange a visit in person with any or all of the bidder's clients. Reference and credit checks may be grounds to reject a proposal, withdraw an intent to award, or rescind the award of a contract.

**W. AWARD**

The State reserves the right to evaluate proposals and award contracts in a manner utilizing criteria selected at the State's discretion and in the State's best interest. After evaluation of the proposals, or at any point in the RFP process, the State of Nebraska may take one or more of the following actions:

1. Amend the RFP;
2. Extend the time of or establish a new proposal opening time;
3. Waive deviations or errors in the State's RFP process and in bidder proposals that are not material, do not compromise the RFP process or a bidder's proposal, and do not improve a bidder's competitive position;
4. Accept or reject a portion of or all of a proposal;
5. Accept or reject all proposals;
6. Withdraw the RFP;
7. Elect to rebid the RFP;
8. Award single lines or multiple lines to one or more bidders; or,
9. Award one or more all-inclusive contracts.

The RFP does not commit the State to award a contract. Once intent to award decision has been determined, it will be posted to the Internet at:

<http://das.nebraska.gov/materiel/purchasing.html>

Grievance and protest procedure is available on the Internet at:

<http://das.nebraska.gov/materiel/purchasing.html>

Any protests must be filed by a bidder within ten (10) business days after the intent to award decision is posted to the Internet.



**II. TERMS AND CONDITIONS**

**Bidders should complete Sections II through VI as part of their proposal.** Bidder is expected to read the Terms and Conditions and should initial either accept, reject, or reject and provide alternative language for each clause. The bidder should also provide an explanation of why the bidder rejected the clause or rejected the clause and provided alternate language. By signing the RFP, bidder is agreeing to be legally bound by all the accepted terms and conditions, and any proposed alternative terms and conditions submitted with the proposal. The State reserves the right to negotiate rejected or proposed alternative language. If the State and bidder fail to agree on the final Terms and Conditions, the State reserves the right to reject the proposal. The State of Nebraska is soliciting proposals in response to this RFP. The State of Nebraska reserves the right to reject proposals that attempt to substitute the bidder's commercial contracts and/or documents for this RFP.

The State will not consider incorporation of any document not submitted with the bidder's proposal as the document will not have been included in the evaluation process. These documents shall be subject to negotiation and will be incorporated as addendums if agreed to by the Parties.

If a conflict or ambiguity arises after the Addendum to Contract Award have been negotiated and agreed to, the Addendum to Contract Award shall be interpreted as follows:

1. If only one Party has a particular clause then that clause shall control;
2. If both Parties have a similar clause, but the clauses do not conflict, the clauses shall be read together;
3. If both Parties have a similar clause, but the clauses conflict, the State's clause shall control.

**F. GENERAL**

Accept (Initial)	Reject (Initial)	Reject & Provide Alternative within RFP Response (Initial)	NOTES/COMMENTS:

The contract resulting from this RFP shall incorporate the following documents:

4. Request for Proposal and Addenda;
5. Amendments to the RFP;
6. Questions and Answers;
7. Contractor's proposal (RFP and properly submitted documents);
8. The executed Contract and Addendum One to Contract, if applicable ; and,
9. Amendments/Addendums to the Contract.

These documents constitute the entirety of the contract.

Unless otherwise specifically stated in a future contract amendment, in case of any conflict between the incorporated documents, the documents shall govern in the following order of preference with number one (1) receiving preference over all other documents and with each lower numbered document having preference over any higher numbered document: 1) Amendment to the executed Contract with the most recent dated amendment having the highest priority, 2) executed Contract and any attached Addenda, 3) Amendments to RFP and any Questions and Answers, 4) the original RFP document and any Addenda, and 5) the Contractor's submitted Proposal.

Any ambiguity or conflict in the contract discovered after its execution, not otherwise addressed herein, shall be resolved in accordance with the rules of contract interpretation as established in the State of Nebraska.

**B. NOTIFICATION**

Accept (Initial)	Reject (Initial)	Reject & Provide Alternative within RFP Response (Initial)	NOTES/COMMENTS:

Contractor and State shall identify the contract manager who shall serve as the point of contact for the executed contract.

Communications regarding the executed contract shall be in writing and shall be deemed to have been given if delivered personally or mailed, by U.S. Mail, postage prepaid, return receipt requested, to the parties at their respective addresses set forth below, or at such other addresses as may be specified in writing by either of the parties. All notices, requests, or communications shall be deemed effective upon personal delivery or three (3) calendar days following deposit in the mail.

Vendor Contract Manager
Vendor
Vendor Street Address
Vendor City, State, Zip

**C. GOVERNING LAW (Statutory)**

Notwithstanding any other provision of this contract, or any amendment or addendum(s) entered into contemporaneously or at a later time, the parties understand and agree that, (1) the State of Nebraska is a sovereign state and its authority to contract is therefore subject to limitation by the State's Constitution, statutes, common law, and regulation; (2) this contract will be interpreted and enforced under the laws of the State of Nebraska; (3) any action to enforce the provisions of this agreement must be brought in the State of Nebraska per state law; (4) the person signing this contract on behalf of the State of Nebraska does not have the authority to waive the State's sovereign immunity, statutes, common law, or regulations; (5) the indemnity, limitation of liability, remedy, and other similar provisions of the final contract, if any, are entered into subject to the State's Constitution, statutes, common law, regulations, and sovereign immunity; and, (6) all terms and conditions of the final contract, including but not limited to the clauses concerning third party use, licenses, warranties, limitations of liability, governing law and venue, usage verification, indemnity, liability, remedy or other similar provisions of the final contract are entered into specifically subject to the State's Constitution, statutes, common law, regulations, and sovereign immunity.

The Parties must comply with all applicable local, state and federal laws, ordinances, rules, orders, and regulations.

**D. BEGINNING OF WORK**

Accept (Initial)	Reject (Initial)	Reject & Provide Alternative within RFP Response (Initial)	NOTES/COMMENTS:

The bidder shall not commence any billable work until a valid contract has been fully executed by the State and the successful Contractor. The Contractor will be notified in writing when work may begin.

**E. CHANGE ORDERS**

Accept (Initial)	Reject (Initial)	Reject & Provide Alternative within RFP Response (Initial)	NOTES/COMMENTS:

The State and the Contractor, upon the written agreement, may make changes to the contract within the general scope of the RFP. Changes may involve specifications, the quantity of work, or such other items as the State may find necessary or desirable. Corrections of any deliverable, service, or work required pursuant to the contract shall not be deemed a change. The Contractor may not claim forfeiture of the contract by reasons of such changes.

The Contractor shall prepare a written description of the work required due to the change and an itemized cost sheet for the change. Changes in work and the amount of compensation to be paid to the Contractor shall be determined in accordance with applicable unit prices if any, a pro-rated value, or through negotiations. The State shall not incur a price increase for changes that should have been included in the Contractor's proposal, were foreseeable, or result from difficulties with or failure of the Contractor's proposal or performance.

No change shall be implemented by the Contractor until approved by the State, and the Contract is amended to reflect the change and associated costs, if any. If there is a dispute regarding the cost, but both parties agree that immediate implementation is necessary, the change may be implemented, and cost negotiations may continue with both Parties retaining all remedies under the contract and law.

**F. NOTICE OF POTENTIAL CONTRACTOR BREACH**

Accept (Initial)	Reject (Initial)	Reject & Provide Alternative within RFP Response (Initial)	NOTES/COMMENTS:

If Contractor breaches the contract or anticipates breaching the contract, the Contractor shall immediately give written notice to the State. The notice shall explain the breach or potential breach, a proposed cure, and may include a request for a waiver of the breach if so desired. The State may, in its discretion, temporarily or permanently waive the breach. By granting a waiver, the State does not forfeit any rights or remedies to which the State is entitled by law or equity, or pursuant to the provisions of the contract. Failure to give immediate notice, however, may be grounds for denial of any request for a waiver of a breach.

**G. BREACH**

Accept (Initial)	Reject (Initial)	Reject & Provide Alternative within RFP Response (Initial)	NOTES/COMMENTS:

Either Party may terminate the contract, in whole or in part, if the other Party breaches its duty to perform its obligations under the contract in a timely and proper manner. Termination requires written notice of default and a thirty (30) calendar day (or longer at the non-breaching Party's discretion considering the gravity and nature of the default) cure period. Said notice shall be delivered by Certified Mail, Return Receipt Requested, or in person with proof of delivery. Allowing time to cure a failure or breach of contract does not waive the right to immediately terminate the contract for the same or different contract breach which may occur at a different time. In case of default of the Contractor, the State may contract the service from other sources and hold the Contractor responsible for any excess cost occasioned thereby.

The State's failure to make payment shall not be a breach, and the Contractor shall retain all available statutory remedies and protections.

**H. NON-WAIVER OF BREACH**

Accept (Initial)	Reject (Initial)	Reject & Provide Alternative within RFP Response (Initial)	NOTES/COMMENTS:

The acceptance of late performance with or without objection or reservation by a Party shall not waive any rights of the Party nor constitute a waiver of the requirement of timely performance of any obligations remaining to be performed.

**I. SEVERABILITY**

Accept (Initial)	Reject (Initial)	Reject & Provide Alternative within RFP Response (Initial)	NOTES/COMMENTS:

If any term or condition of the contract is declared by a court of competent jurisdiction to be illegal or in conflict with any law, the validity of the remaining terms and conditions shall not be affected, and the rights and obligations of the parties shall be construed and enforced as if the contract did not contain the provision held to be invalid or illegal.

**J. INDEMNIFICATION**

Accept (Initial)	Reject (Initial)	Reject & Provide Alternative within RFP Response (Initial)	NOTES/COMMENTS:

**1. GENERAL**

The Contractor agrees to defend, indemnify, and hold harmless the State and its employees, volunteers, agents, and its elected and appointed officials ("the indemnified parties") from and against any and all third party claims, liens, demands, damages, liability, actions, causes of action, losses, judgments, costs, and expenses of every nature, including investigation costs and expenses, settlement costs, and attorney fees and expenses ("the claims"), sustained or asserted against the State for personal injury, death, or property loss or damage, arising out of, resulting from, or attributable to the willful misconduct, negligence, error, or omission of the Contractor, its employees, Subcontractors, consultants, representatives, and agents, resulting from this contract, except to the extent such Contractor liability is attenuated by any action of the State which directly and proximately contributed to the claims.

**2. INTELLECTUAL PROPERTY**

The Contractor agrees it will, at its sole cost and expense, defend, indemnify, and hold harmless the indemnified parties from and against any and all claims, to the extent such claims arise out of, result from, or are attributable to, the actual or alleged infringement or misappropriation of any patent, copyright, trade secret, trademark, or confidential information of any third party by the Contractor or its employees, Subcontractors, consultants, representatives, and agents; provided, however, the State gives the Contractor prompt notice in writing of the claim. The Contractor may not settle any infringement claim that will affect

the State's use of the Licensed Software without the State's prior written consent, which consent may be withheld for any reason.

If a judgment or settlement is obtained or reasonably anticipated against the State's use of any intellectual property for which the Contractor has indemnified the State, the Contractor shall, at the Contractor's sole cost and expense, promptly modify the item or items which were determined to be infringing, acquire a license or licenses on the State's behalf to provide the necessary rights to the State to eliminate the infringement, or provide the State with a non-infringing substitute that provides the State the same functionality. At the State's election, the actual or anticipated judgment may be treated as a breach of warranty by the Contractor, and the State may receive the remedies provided under this RFP.

**3. PERSONNEL**

The Contractor shall, at its expense, indemnify and hold harmless the indemnified parties from and against any claim with respect to withholding taxes, worker's compensation, employee benefits, or any other claim, demand, liability, damage, or loss of any nature relating to any of the personnel, including subcontractor's and their employees, provided by the Contractor.

**4. SELF-INSURANCE**

The State of Nebraska is self-insured for any loss and purchases excess insurance coverage pursuant to Neb. Rev. Stat. § 81-8,239.01 (Reissue 2008). If there is a presumed loss under the provisions of this agreement, Contractor may file a claim with the Office of Risk Management pursuant to Neb. Rev. Stat. §§ 81-8,829 – 81-8,306 for review by the State Claims Board. The State retains all rights and immunities under the State Miscellaneous (Section 81-8,294), Tort (Section 81-8,209), and Contract Claim Acts (Section 81-8,302), as outlined in Neb. Rev. Stat. § 81-8,209 et seq. and under any other provisions of law and accepts liability under this agreement to the extent provided by law.

5. The Parties acknowledge that Attorney General for the State of Nebraska is required by statute to represent the legal interests of the State, and that any provision of this indemnity clause is subject to the statutory authority of the Attorney General.

**K. ATTORNEY'S FEES**

Accept (Initial)	Reject (Initial)	Reject & Provide Alternative within RFP Response (Initial)	NOTES/COMMENTS:

In the event of any litigation, appeal, or other legal action to enforce any provision of the contract, the Parties agree to pay all expenses of such action, as permitted by law and if order by the court, including attorney's fees and costs, if the other Party prevails.

**L. RETAINAGE**

Accept (Initial)	Reject (Initial)	Reject & Provide Alternative within RFP Response (Initial)	NOTES/COMMENTS:

The State will withhold ten percent (10%) of each payment due as retainage. The entire retainage amount will be payable upon successful completion of the project phase. Upon completion of the project, the Contractor will invoice the State for any outstanding work and for the retainage. The State may reject the final invoice by identifying the specific reasons for such rejection in writing to the Contractor within forty-five (45) calendar days of receipt of the final invoice. Otherwise, the project will be deemed accepted and the State will release the final payment and retainage in accordance with the contract payment terms.

**M. ASSIGNMENT, SALE, OR MERGER**

Accept (Initial)	Reject (Initial)	Reject & Provide Alternative within RFP Response (Initial)	NOTES/COMMENTS:

Either Party may assign the contract upon mutual written agreement of the other Party. Such agreement shall not be unreasonably withheld.

The Contractor retains the right to enter into a sale, merger, acquisition, internal reorganization, or similar transaction involving Contractor's business. Contractor agrees to cooperate with the State in executing amendments to the contract to allow for the transaction. If a third party or entity is involved in the transaction, the Contractor will remain responsible for performance of the contract until such time as the person or entity involved in the transaction agrees in writing to be contractually bound by this contract and perform all obligations of the contract.

**N. CONTRACTING WITH OTHER NEBRASKA POLITICAL SUB-DIVISIONS**

Accept (Initial)	Reject (Initial)	Reject & Provide Alternative within RFP Response (Initial)	NOTES/COMMENTS:

The Contractor may, but shall not be required to, allow agencies, as defined in Neb. Rev. Stat. §81-145, to use this contract. The terms and conditions, including price, of the contract may not be amended. The State shall not be contractually obligated or liable for any contract entered into pursuant to this clause. A listing of Nebraska political subdivisions may be found at the website of the Nebraska Auditor of Public Accounts.

**O. FORCE MAJEURE**

Accept (Initial)	Reject (Initial)	Reject & Provide Alternative within RFP Response (Initial)	NOTES/COMMENTS:

Neither Party shall be liable for any costs or damages, or for default resulting from its inability to perform any of its obligations under the contract due to a natural or manmade event outside the control and not the fault of the affected Party ("Force Majeure Event"). The Party so affected shall immediately make a written request for relief to the other Party, and shall have the burden of proof to justify the request. The other Party may grant the relief requested; relief may not be unreasonably withheld. Labor disputes with the impacted Party's own employees will not be considered a Force Majeure Event.

**P. CONFIDENTIALITY**

Accept (Initial)	Reject (Initial)	Reject & Provide Alternative within RFP Response (Initial)	NOTES/COMMENTS:

All materials and information provided by the Parties or acquired by a Party on behalf of the other Party shall be regarded as confidential information. All materials and information provided or acquired shall be handled in accordance with federal and state law, and ethical standards. Should said confidentiality be breached by a Party, the Party shall notify the other Party immediately of said breach and take immediate corrective action.

It is incumbent upon the Parties to inform their officers and employees of the penalties for improper disclosure imposed by the Privacy Act of 1974, 5 U.S.C. 552a. Specifically, 5 U.S.C. 552a (i)(1), which is made applicable by 5 U.S.C. 552a (m)(1), provides that any officer or employee, who by virtue of his/her employment or official position has possession of or access to agency records which contain individually identifiable information, the disclosure of which is prohibited by the Privacy Act or regulations established thereunder, and who knowing that disclosure of the specific material is prohibited, willfully discloses the material in any manner to any person or agency not entitled to receive it, shall be guilty of a misdemeanor and fined not more than \$5,000.

**Q. EARLY TERMINATION**

Accept (Initial)	Reject (Initial)	Reject & Provide Alternative within RFP Response (Initial)	NOTES/COMMENTS:

The contract may be terminated as follows:

1. The State and the Contractor, by mutual written agreement, may terminate the contract at any time.
2. The State, in its sole discretion, may terminate the contract for any reason upon thirty (30) calendar day's written notice to the Contractor. Such termination shall not relieve the Contractor of warranty or other service obligations incurred under the terms of the contract. In the event of termination the Contractor shall be entitled to payment, determined on a pro rata basis, for products or services satisfactorily performed or provided.
3. The State may terminate the contract immediately for the following reasons:
  - a. if directed to do so by statute;
  - b. Contractor has made an assignment for the benefit of creditors, has admitted in writing its inability to pay debts as they mature, or has ceased operating in the normal course of business;
  - c. a trustee or receiver of the Contractor or of any substantial part of the Contractor's assets has been appointed by a court;
  - d. fraud, misappropriation, embezzlement, malfeasance, misfeasance, or illegal conduct pertaining to performance under the contract by its Contractor, its employees, officers, directors, or shareholders;
  - e. an involuntary proceeding has been commenced by any Party against the Contractor under any one of the chapters of Title 11 of the United States Code and (i) the proceeding has been pending for at least sixty (60) calendar days; or (ii) the Contractor has consented, either expressly or by operation of law, to the entry of an order for relief; or (iii) the Contractor has been decreed or adjudged a debtor;
  - f. a voluntary petition has been filed by the Contractor under any of the chapters of Title 11 of the United States Code;
  - g. Contractor intentionally discloses confidential information;
  - h. Contractor has or announces it will discontinue support of the deliverable; and,
  - i. In the event funding is no longer available.

**R. CONTRACT CLOSEOUT**

Accept (Initial)	Reject (Initial)	Reject & Provide Alternative within RFP Response (Initial)	NOTES/COMMENTS:

Upon contract closeout for any reason the Contractor shall within 30 days, unless stated otherwise herein:

1. Transfer all completed or partially completed deliverables to the State;
2. Transfer ownership and title to all completed or partially completed deliverables to the State;
3. Return to the State all information and data, unless the Contractor is permitted to keep the information or data by contract or rule of law. Contractor may retain one copy of any information or data as required to comply with applicable work product documentation standards or as are automatically retained in the course of Contractor's routine back up procedures;
4. Cooperate with any successor Contractor, person or entity in the assumption of any or all of the obligations of this contract;
5. Cooperate with any successor Contractor, person or entity with the transfer of information or data related to this contract;
6. Return or vacate any state owned real or personal property; and,
7. Return all data in a mutually acceptable format and manner.

Nothing in this Section should be construed to require the Contractor to surrender intellectual property, real or personal property, or information or data owned by the Contractor for which the State has no legal claim.



### III. CONTRACTOR DUTIES

#### A. INDEPENDENT CONTRACTOR / OBLIGATIONS

Accept (Initial)	Reject (Initial)	Reject & Provide Alternative within RFP Response (Initial)	NOTES/COMMENTS:

It is agreed that the Contractor is an independent contractor and that nothing contained herein is intended or should be construed as creating or establishing a relationship of employment, agency, or a partnership.

The Contractor is solely responsible for fulfilling the contract. The Contractor or the Contractor's representative shall be the sole point of contact regarding all contractual matters.

The Contractor shall secure, at its own expense, all personnel required to perform the services under the contract. The personnel the Contractor uses to fulfill the contract shall have no contractual or other legal relationship with the State; they shall not be considered employees of the State and shall not be entitled to any compensation, rights or benefits from the State, including but not limited to, tenure rights, medical and hospital care, sick and vacation leave, severance pay, or retirement benefits.

By-name personnel commitments made in the Contractor's proposal shall not be changed without the prior written approval of the State. Replacement of these personnel, if approved by the State, shall be with personnel of equal or greater ability and qualifications.

All personnel assigned by the Contractor to the contract shall be employees of the Contractor or a subcontractor, and shall be fully qualified to perform the work required herein. Personnel employed by the Contractor or a subcontractor to fulfill the terms of the contract shall remain under the sole direction and control of the Contractor or the subcontractor respectively.

With respect to its employees, the Contractor agrees to be solely responsible for the following:

1. Any and all pay, benefits, and employment taxes and/or other payroll withholding;
2. Any and all vehicles used by the Contractor's employees, including all insurance required by state law;
3. Damages incurred by Contractor's employees within the scope of their duties under the contract;
4. Maintaining Workers' Compensation and health insurance that complies with state and federal law and submitting any reports on such insurance to the extent required by governing law; and
5. Determining the hours to be worked and the duties to be performed by the Contractor's employees.
6. All claims on behalf of any person arising out of employment or alleged employment (including without limit claims of discrimination alleged against the Contractor, its officers, agents, or subcontractors or subcontractor's employees)

If the Contractor intends to utilize any subcontractor, the subcontractor's level of effort, tasks, and time allocation should be clearly defined in the bidder's proposal. The Contractor shall agree that it will not utilize any subcontractors not specifically included in its proposal in the performance of the contract without the prior written authorization of the State.

The State reserves the right to require the Contractor to reassign or remove from the project any Contractor or subcontractor employee.

Contractor shall insure that the terms and conditions contained in any contract with a subcontractor does not conflict with the terms and conditions of this contract.

The Contractor shall include a similar provision, for the protection of the State, in the contract with any Subcontractor engaged to perform work on this contract.

**B. EMPLOYEE WORK ELIGIBILITY STATUS**

Accept (Initial)	Reject (Initial)	Reject & Provide Alternative within RFP Response (Initial)	NOTES/COMMENTS:

The Contractor is required and hereby agrees to use a federal immigration verification system to determine the work eligibility status of employees physically performing services within the State of Nebraska. A federal immigration verification system means the electronic verification of the work authorization program authorized by the Illegal Immigration Reform and Immigrant Responsibility Act of 1996, 8 U.S.C. 1324a, known as the E-Verify Program, or an equivalent federal program designated by the United States Department of Homeland Security or other federal agency authorized to verify the work eligibility status of an employee.

If the Contractor is an individual or sole proprietorship, the following applies:

1. The Contractor must complete the United States Citizenship Attestation Form, available on the Department of Administrative Services website at <http://das.nebraska.gov/materiel/purchasing.html>  
The completed United States Attestation Form should be submitted with the RFP response.
2. If the Contractor indicates on such attestation form that he or she is a qualified alien, the Contractor agrees to provide the US Citizenship and Immigration Services documentation required to verify the Contractor's lawful presence in the United States using the Systematic Alien Verification for Entitlements (SAVE) Program.
3. The Contractor understands and agrees that lawful presence in the United States is required and the Contractor may be disqualified or the contract terminated if such lawful presence cannot be verified as required by Neb. Rev. Stat. §4-108.

**C. COMPLIANCE WITH CIVIL RIGHTS LAWS AND EQUAL OPPORTUNITY EMPLOYMENT / NONDISCRIMINATION (Statutory)**

The Contractor shall comply with all applicable local, state, and federal statutes and regulations regarding civil rights laws and equal opportunity employment. The Nebraska Fair Employment Practice Act prohibits Contractors of the State of Nebraska, and their Subcontractors, from discriminating against any employee or applicant for employment, with respect to hire, tenure, terms, conditions, compensation, or privileges of employment because of race, color, religion, sex, disability, marital status, or national origin (Neb. Rev. Stat. §48-1101 to 48-1125). The Contractor guarantees compliance with the Nebraska Fair Employment Practice Act, and breach of this provision shall be regarded as a material breach of contract. The Contractor shall insert a similar provision in all Subcontracts for services to be covered by any contract resulting from this RFP.

**D. COOPERATION WITH OTHER CONTRACTORS**

Accept (Initial)	Reject (Initial)	Reject & Provide Alternative within RFP Response (Initial)	NOTES/COMMENTS:

Contractor may be required to work with or in close proximity to other contractors or individuals that may be working on same or different projects. The Contractor shall agree to cooperate with such other contractors or individuals, and shall not commit or permit any act which may interfere with the performance of work by any other contractor or individual. Contractor is not required to compromise Contractor's intellectual property or proprietary information unless expressly required to do so by this contract.

**E. PERMITS, REGULATIONS, LAWS**

Accept (Initial)	Reject (Initial)	Reject & Provide Alternative within RFP Response (Initial)	NOTES/COMMENTS:

The contract price shall include the cost of all royalties, licenses, permits, and approvals, whether arising from patents, trademarks, copyrights or otherwise, that are in any way involved in the contract. The Contractor shall obtain and pay for all royalties, licenses, and permits, and approvals necessary for the execution of the contract. The Contractor must guarantee that it has the full legal right to the materials, supplies, equipment, software, and other items used to execute this contract.

**F. OWNERSHIP OF INFORMATION AND DATA / DELIVERABLES**

Accept (Initial)	Reject (Initial)	Reject & Provide Alternative within RFP Response (Initial)	NOTES/COMMENTS:

The State shall have the unlimited right to publish, duplicate, use, and disclose all information and data developed or obtained by the Contractor on behalf of the State pursuant to this contract.

The State shall own and hold exclusive title to any deliverable developed as a result of this contract. Contractor shall have no ownership interest or title, and shall not patent, license, or copyright, duplicate, transfer, sell, or exchange, the design, specifications, concept, or deliverable.

**G. INSURANCE REQUIREMENTS**

Accept (Initial)	Reject (Initial)	Reject & Provide Alternative within RFP Response (Initial)	NOTES/COMMENTS:

The Contractor shall throughout the term of the contract maintain insurance as specified herein and provide the State a current Certificate of Insurance/Acord Form (COI) verifying the coverage. The Contractor shall not commence work on the contract until the insurance is in place. If Contractor subcontracts any portion of the Contract the Contractor must, throughout the term of the contract, either:

1. Provide equivalent insurance for each subcontractor and provide a COI verifying the coverage for the subcontractor;
2. Require each subcontractor to have equivalent insurance and provide written notice to the State that the Contractor has verified that each subcontractor has the required coverage; or,
3. Provide the State with copies of each subcontractor's Certificate of Insurance evidencing the required coverage.

The Contractor shall not allow any Subcontractor to commence work until the Subcontractor has equivalent insurance. The failure of the State to require a COI, or the failure of the Contractor to provide a COI or require subcontractor insurance shall not limit, relieve, or decrease the liability of the Contractor hereunder.

In the event that any policy written on a claims-made basis terminates or is canceled during the term of the contract or within one (1) year of termination or expiration of the contract, the contractor shall obtain an extended discovery

or reporting period, or a new insurance policy, providing coverage required by this contract for the term of the contract and one (1) year following termination or expiration of the contract.

If by the terms of any insurance a mandatory deductible is required, or if the Contractor elects to increase the mandatory deductible amount, the Contractor shall be responsible for payment of the amount of the deductible in the event of a paid claim.

Notwithstanding any other clause in this Contract, the State may recover up to the liability limits of the insurance policies required herein.

**1. WORKERS' COMPENSATION INSURANCE**

The Contractor shall take out and maintain during the life of this contract the statutory Workers' Compensation and Employer's Liability Insurance for all of the contactors' employees to be engaged in work on the project under this contract and, in case any such work is sublet, the Contractor shall require the Subcontractor similarly to provide Worker's Compensation and Employer's Liability Insurance for all of the Subcontractor's employees to be engaged in such work. This policy shall be written to meet the statutory requirements for the state in which the work is to be performed, including Occupational Disease. **The policy shall include a waiver of subrogation in favor of the State. The COI shall contain the mandatory COI subrogation waiver language found hereinafter.** The amounts of such insurance shall not be less than the limits stated hereinafter. For employees working in the State of Nebraska, the policy must be written by an entity authorized by the State of Nebraska Department of Insurance to write Workers' Compensation and Employer's Liability Insurance for Nebraska employees.

**4. COMMERCIAL GENERAL LIABILITY INSURANCE AND COMMERCIAL AUTOMOBILE LIABILITY INSURANCE**

The Contractor shall take out and maintain during the life of this contract such Commercial General Liability Insurance and Commercial Automobile Liability Insurance as shall protect Contractor and any Subcontractor performing work covered by this contract from claims for damages for bodily injury, including death, as well as from claims for property damage, which may arise from operations under this contract, whether such operation be by the Contractor or by any Subcontractor or by anyone directly or indirectly employed by either of them, and the amounts of such insurance shall not be less than limits stated hereinafter.

The Commercial General Liability Insurance shall be written on an **occurrence basis**, and provide Premises/Operations, Products/Completed Operations, Independent Contractors, Personal Injury, and Contractual Liability coverage. **The policy shall include the State, and others as required by the contract documents, as Additional Insured(s). This policy shall be primary, and any insurance or self-insurance carried by the State shall be considered secondary and non-contributory. The COI shall contain the mandatory COI liability waiver language found hereinafter.** The Commercial Automobile Liability Insurance shall be written to cover all Owned, Non-owned, and Hired vehicles.

<b>REQUIRED INSURANCE COVERAGE</b>	
<b>COMMERCIAL GENERAL LIABILITY</b>	
General Aggregate	\$2,000,000
Products/Completed Operations Aggregate	\$2,000,000
Personal/Advertising Injury	\$1,000,000 per occurrence
Bodily Injury/Property Damage	\$1,000,000 per occurrence
Medical Payments	\$10,000 any one person
Damage to Rented Premises (Fire)	\$300,000 each occurrence
Contractual	Included
XCU Liability (Explosion, Collapse, and Underground Damage)	Included
Independent Contractors	Included
Abuse & Molestation	Included
<i>If higher limits are required, the Umbrella/Excess Liability limits are allowed to satisfy the higher limit.</i>	
<b>WORKER'S COMPENSATION</b>	
Employers Liability Limits	\$500K/\$500K/\$500K
Statutory Limits- All States	Statutory - State of Nebraska
USL&H Endorsement	Statutory
Voluntary Compensation	Statutory
<b>COMMERCIAL AUTOMOBILE LIABILITY</b>	
Bodily Injury/Property Damage	\$1,000,000 combined single limit
Include All Owned, Hired & Non-Owned Automobile liability	Included
Motor Carrier Act Endorsement	Where Applicable
<b>UMBRELLA/EXCESS LIABILITY</b>	
Over Primary Insurance	\$5,000,000 per occurrence
<b>PROFESSIONAL LIABILITY</b>	
All Other Professional Liability (Errors & Omissions)	\$1,000,000 Per Claim / Aggregate
<b>COMMERCIAL CRIME</b>	
Crime/Employee Dishonesty Including 3rd Party Fidelity	\$1,000,000
<b>CYBER LIABILITY</b>	
Breach of Privacy, Security Breach, Denial of Service, Remediation, Fines and Penalties	\$10,000,000
<b>MANDATORY COI SUBROGATION WAIVER LANGUAGE</b>	
"Workers' Compensation policy shall include a waiver of subrogation in favor of the State of Nebraska."	
<b>MANDATORY COI LIABILITY WAIVER LANGUAGE</b>	
"Commercial General Liability & Commercial Automobile Liability policies shall name the State of Nebraska as an Additional Insured and the policies shall be primary and any insurance or self-insurance carried by the State shall be considered secondary and non-contributory as additionally insured."	

If the mandatory COI subrogation waiver language or mandatory COI liability waiver language on the COI states that the waiver is subject to, condition upon, or otherwise limit by the insurance policy, a copy of the relevant sections of the policy must be submitted with the COI so the State can review the limitations imposed by the insurance policy.

**5. EVIDENCE OF COVERAGE**

The Contractor shall furnish the Contract Manager, with a certificate of insurance coverage complying with the above requirements prior to beginning work at:

Nebraska Educational Telecommunications  
 Attn: Contract Manager  
 1800 N. 33<sup>rd</sup> Street  
 Lincoln, NE, 68503

These certificates or the cover sheet shall reference the RFP number, and the certificates shall include the name of the company, policy numbers, effective dates, dates of expiration, and amounts and types of coverage afforded. If the State is damaged by the failure of the Contractor to maintain such insurance, then the Contractor shall be responsible for all reasonable costs properly attributable thereto.

Reasonable notice of cancellation of any required insurance policy must be submitted to the contract manager as listed above when issued and a new coverage binder shall be submitted immediately to ensure no break in coverage.

**6. DEVIATIONS**

The insurance requirements are subject to limited negotiation. Negotiation typically includes, but is not necessarily limited to, the correct type of coverage, necessity for Workers' Compensation, and the type of automobile coverage carried by the Contractor.

**H. ANTITRUST**

Accept (Initial)	Reject (Initial)	Reject & Provide Alternative within RFP Response (Initial)	NOTES/COMMENTS:

The Contractor hereby assigns to the State any and all claims for overcharges as to goods and/or services provided in connection with this contract resulting from antitrust violations which arise under antitrust laws of the United States and the antitrust laws of the State.

**I. CONFLICT OF INTEREST**

Accept (Initial)	Reject (Initial)	Reject & Provide Alternative within RFP Response (Initial)	NOTES/COMMENTS:

By submitting a proposal, bidder certifies that there does not now exist a relationship between the bidder and any person or entity which is or gives the appearance of a conflict of interest related to this RFP or project.

The bidder certifies that it shall not take any action or acquire any interest, either directly or indirectly, which will conflict in any manner or degree with the performance of its services hereunder or which creates an actual or an appearance of conflict of interest.

The bidder certifies that it will not knowingly employ any individual known by bidder to have a conflict of interest.

The Parties shall not knowingly, for a period of two years after execution of the contract, recruit or employ any employee or agent of the other Party who has worked on the RFP or project, or who had any influence on decisions affecting the RFP or project.

**J. STATE PROPERTY**

Accept (Initial)	Reject (Initial)	Reject & Provide Alternative within RFP Response (Initial)	NOTES/COMMENTS:

The Contractor shall be responsible for the proper care and custody of any State-owned property which is furnished for the Contractor's use during the performance of the contract. The Contractor shall reimburse the State for any loss or damage of such property; normal wear and tear is expected.

**K. SITE RULES AND REGULATIONS**

Accept (Initial)	Reject (Initial)	Reject & Provide Alternative within RFP Response (Initial)	NOTES/COMMENTS:

The Contractor shall use its best efforts to ensure that its employees, agents, and Subcontractors comply with site rules and regulations while on State premises. If the Contractor must perform on-site work outside of the daily operational hours set forth by the State, it must make arrangements with the State to ensure access to the facility and the equipment has been arranged. No additional payment will be made by the State on the basis of lack of access, unless the State fails to provide access as agreed to in writing between the State and the Contractor.

**L. ADVERTISING**

Accept (Initial)	Reject (Initial)	Reject & Provide Alternative within RFP Response (Initial)	NOTES/COMMENTS:

The Contractor agrees not to refer to the contract award in advertising in such a manner as to state or imply that the company or its services are endorsed or preferred by the State. Any publicity releases pertaining to the project shall not be issued without prior written approval from the State.

**M. NEBRASKA TECHNOLOGY ACCESS STANDARDS (Statutory)**

Contractor shall review the Nebraska Technology Access Standards, found at <http://nitc.nebraska.gov/standards/2-201.html> and ensure that products and/or services provided under the contract are in compliance or will comply with the applicable standards to the greatest degree possible. In the event such standards change during the Contractor's performance, the State may create an amendment to the contract to request the contract comply with the changed standard at a cost mutually acceptable to the parties.

**N. DISASTER RECOVERY/BACK UP PLAN**

Accept (Initial)	Reject (Initial)	Reject & Provide Alternative within RFP Response (Initial)	NOTES/COMMENTS:

The Contractor shall have a disaster recovery and back-up plan, of which a copy should be provided upon request to the State, which includes, but is not limited to equipment, personnel, facilities, and transportation, in order to continue services as specified under the specifications in the contract in the event of a disaster.

**O. DRUG POLICY**

Accept (Initial)	Reject (Initial)	Reject & Provide Alternative within RFP Response (Initial)	NOTES/COMMENTS:

Contractor certifies it maintains a drug free work place environment to ensure worker safety and workplace integrity. Contractor agrees to provide a copy of its drug free workplace policy at any time upon request by the State.



**IV. PAYMENT**

**A. PROHIBITION AGAINST ADVANCE PAYMENT (Statutory)**

Payments shall not be made until contractual deliverable(s) are received and accepted by the State.

**B. TAXES (Statutory)**

The State is not required to pay taxes and assumes no such liability as a result of this solicitation. Any property tax payable on the Contractor's equipment which may be installed in a state-owned facility is the responsibility of the Contractor.

**B. INVOICES**

Accept (Initial)	Reject (Initial)	Reject & Provide Alternative within RFP Response (Initial)	NOTES/COMMENTS:

Invoices for payments must be submitted by the Contractor to the agency requesting the services with sufficient detail to support payment. Invoices for payment shall be submitted to Nebraska Educational Telecommunications 1800 N. 33rd Street, Lincoln, Nebraska, 68503. The terms and conditions included in the Contractor's invoice shall be deemed to be solely for the convenience of the parties. No terms or conditions of any such invoice shall be binding upon the State, and no action by the State, including without limitation the payment of any such invoice in whole or in part, shall be construed as binding or estopping the State with respect to any such term or condition, unless the invoice term or condition has been previously agreed to by the State as an amendment to the contract.

**C. INSPECTION AND APPROVAL**

Accept (Initial)	Reject (Initial)	Reject & Provide Alternative within RFP Response (Initial)	NOTES/COMMENTS:

Final inspection and approval of all work required under the contract shall be performed by the designated State officials.

The State and/or its authorized representatives shall have the right to enter any premises where the Contractor or Subcontractor duties under the contract are being performed, and to inspect, monitor or otherwise evaluate the work being performed. All inspections and evaluations shall be at reasonable times and in a manner that will not unreasonably delay work.

**D. PAYMENT**

Accept (Initial)	Reject (Initial)	Reject & Provide Alternative within RFP Response (Initial)	NOTES/COMMENTS:

State will render payment to Contractor when the terms and conditions of the contract and specifications have been satisfactorily completed on the part of the Contractor as solely determined by the State. (Neb. Rev. Stat. Section 73-506(1)) Payment will be made by the responsible agency in compliance with the State of Nebraska Prompt Payment

Act (See Neb. Rev. Stat. §81-2401 through 81-2408). The State may require the Contractor to accept payment by electronic means such as ACH deposit. In no event shall the State be responsible or liable to pay for any services provided by the Contractor prior to the Effective Date of the contract, and the Contractor hereby waives any claim or cause of action for any such services. No payment shall be made prior to the delivery of any hardware or software; all shipments will be FOB destination.

**E. LATE PAYMENT (Statutory)**

The Contractor may charge the responsible agency interest for late payment in compliance with the State of Nebraska Prompt Payment Act (See Neb. Rev. Stat. §81-2401 through 81-2408).

**F. SUBJECT TO FUNDING / FUNDING OUT CLAUSE FOR LOSS OF APPROPRIATIONS**

Accept (Initial)	Reject (Initial)	Reject & Provide Alternative within RFP Response (Initial)	NOTES/COMMENTS:

The State's obligation to pay amounts due on the Contract for a fiscal years following the current fiscal year is contingent upon legislative appropriation of funds. Should said funds not be appropriated, the State may terminate the contract with respect to those payments for the fiscal year(s) for which such funds are not appropriated. The State will give the Contractor written notice thirty (30) calendar days prior to the effective date of termination. All obligations of the State to make payments after the termination date will cease. The Contractor shall be entitled to receive just and equitable compensation for any authorized work which has been satisfactorily completed as of the termination date. In no event shall the Contractor be paid for a loss of anticipated profit.

**G. RIGHT TO AUDIT (First Paragraph is Statutory)**

Accept (Initial)	Reject (Initial)	Reject & Provide Alternative within RFP Response (Initial)	NOTES/COMMENTS:

The State shall have the right to audit the Contractor's performance of this contract upon a 30 days' written notice. Contractor shall utilize generally accepted accounting principles, and shall maintain the accounting records, and other records and information relevant to the contract (Information) to enable the State to audit the contract. The State may audit and the Contractor shall maintain, the Information during the term of the contract and for a period of five (5) years after the completion of this contract or until all issues or litigation are resolved, whichever is later. The Contractor shall make the Information available to the State at Contractor's place of business or a location acceptable to both Parties during normal business hours. If this is not practical or the Contractor so elects, the Contractor may provide electronic or paper copies of the Information. The State reserves the right to examine, make copies of, and take notes on any Information relevant to this contract, regardless of the form or the Information, how it is stored, or who possesses the Information. Under no circumstance will the Contractor be required to create or maintain documents not kept in the ordinary course of contractor's business operations, nor will contractor be required to disclose any information, including but not limited to product cost data, which is confidential or proprietary to contractor.

The Parties shall pay their own costs of the audit unless the audit finds a previously undisclosed overpayment by the State. If a previously undisclosed overpayment exceeds one percent (.1% of the total contract billings, or if fraud, material misrepresentations, or non-performance is discovered on the part of the Contractor, the Contractor shall reimburse the State for the total costs of the audit. Overpayments and audit costs owed to the State shall be paid within ninety days of written notice of the claim. The Contractor agrees to correct any material weaknesses or condition found as a result of the audit.

## **V. PROJECT DESCRIPTION AND SCOPE OF WORK**

The bidder should provide the following information in response to this RFP.

### **A. PROJECT OVERVIEW**

Nebraska Educational Telecommunications Commission (NETC) uses the Industrial Logic Corporation (ILC) MaxView System purchased in 2000 for its Network Monitoring and Control needs. The current ILC MaxView system is maintained by NETC Engineering and it is operational and functional. However, the system is dated and needs to be updated, refreshed or replaced to accommodate newer technologies and support the latest best practices approach for a Network Management Control System (NMCS). NETC intends to purchase a replacement NMCS for the purpose of controlling and monitoring its Television and Radio broadcast and non-broadcast facilities, including but not limited to:

1. Television and Radio Transmission sites across the State of Nebraska
2. Television and Radio Satellite Teleport
3. Television and Radio Building Facilities

And further expanding it to control and monitor broadcast and non-broadcast operations systems including but not limited to:

1. Television and Radio Terminal Equipment and Production Matrix Routers
2. Television and Radio Master Control, Production Studios and Remote Systems
3. Television and Radio Web Services and IT Networking Systems
4. NETC Government Services Audio-Video Systems

Over time, integrating all existing systems under one unified control and monitoring system as well as providing a centralized control to simplify the transition to new IP based systems while maintaining the same control surface for the operators. Operational efficiency will be achieved by allowing core hardware components to be freely exchanged without changing interfaces or workflows for operational and technical staff.

### **B. SCOPE OF WORK**

NETC intends to purchase a NMCS for the purpose of replacing the existing NMCS and allowing NETC to take advantage of newer technologies and expand the system into other areas of NETC. NETC is planning on a phased approach for installation, integration, and implementation of such products and/or systems which would meet or exceed the NMCS requirements stated in this RFP. The project is estimated to be completed within 3 years upon awarding the contract. NETC will work with awarded bidder to select, choose, combine, alter, or split bidder proposed phases for the phased approach installation, integration and implementation that best fit NETC organizational strategy, annual budget and equipment refreshment needs.

NETC invites innovative solutions that will simplify and optimize existing NMCS workflows and practices to drive down cost and also provide a uniformed platform for all technical functional areas listed in this RFP.

### **C. CURRENT PROJECT ENVIRONMENT**

NETC's main facilities and all of the remote transmission sites are interconnected via a terrestrial broadband network with 50Mbps or 100Mbps connectivity via various VLAN's. The terrestrial broadband connectivity is provided by Network Nebraska. NETC's Television and Radio main multicast broadcast services, monitoring and control signals, and return multicast video/audio signals are all on the same broadband private network.

The current NMCS (ILC MaxView) operates at the NETC main facility and nine (9) full power television and radio transmitter sites located across the State of Nebraska. The existing NMCS graphical user interface provides control and monitoring of the NETC broadcast television and radio transmission sites across the State of Nebraska, the NETC Satellite Teleports, and the NETC building facilities and terminal equipment.

The attached screen captures are a few examples of the NETC NMCS graphical user interface panels currently being used in the MaxView system at NETC.

## Overview monitoring

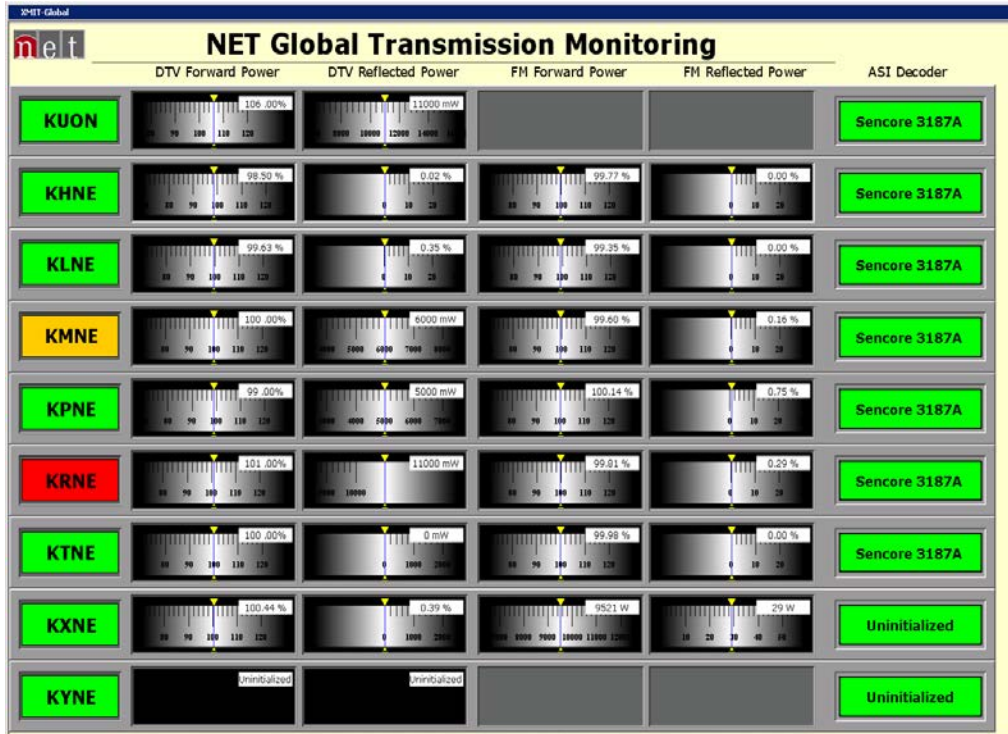

## NETC XMIT-NMCS GUI

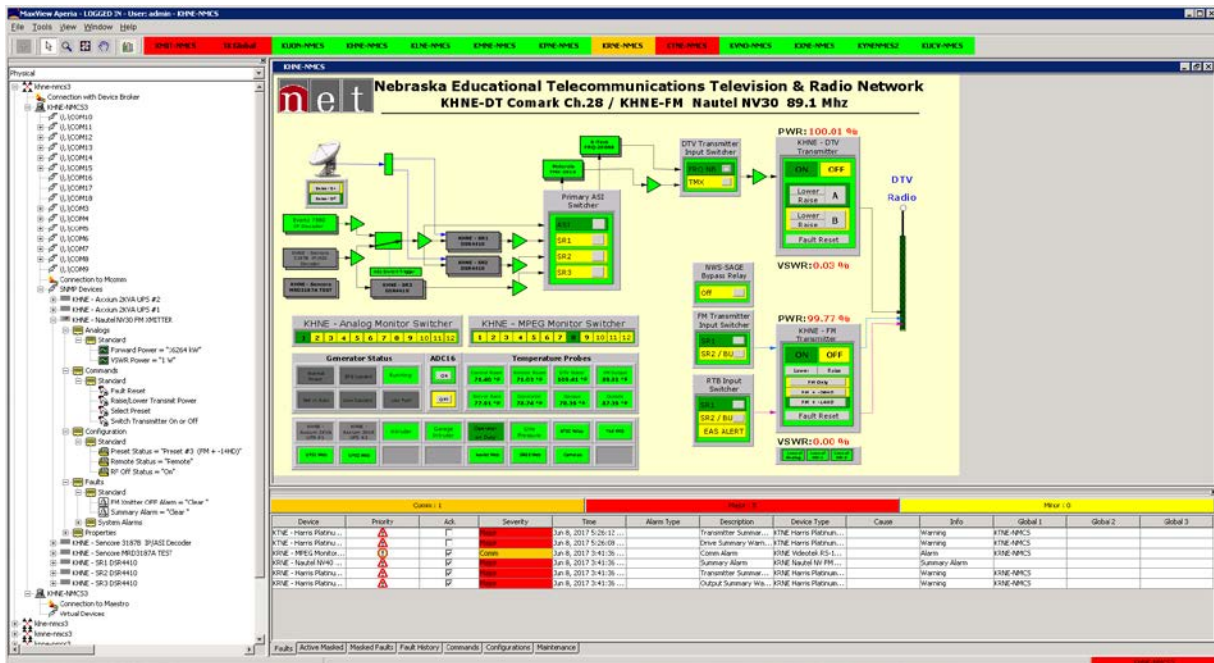

One of the NETC remote transmission sites

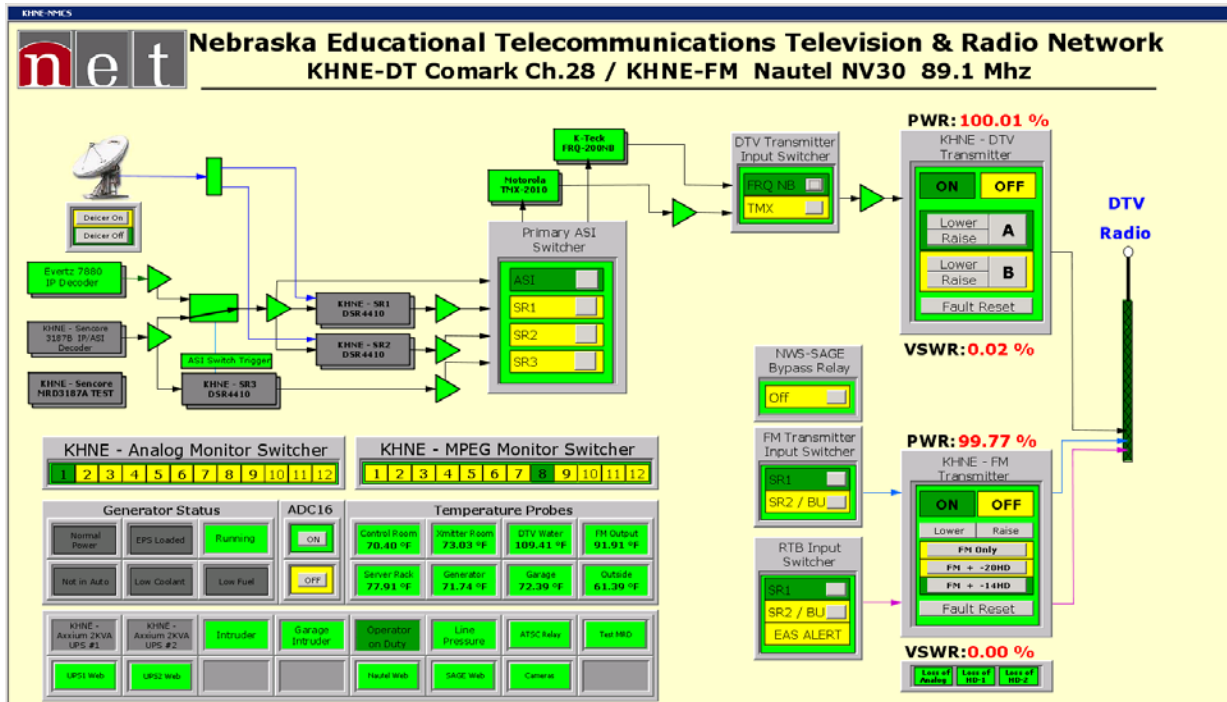

# NETC Teleport

## Operators Panel

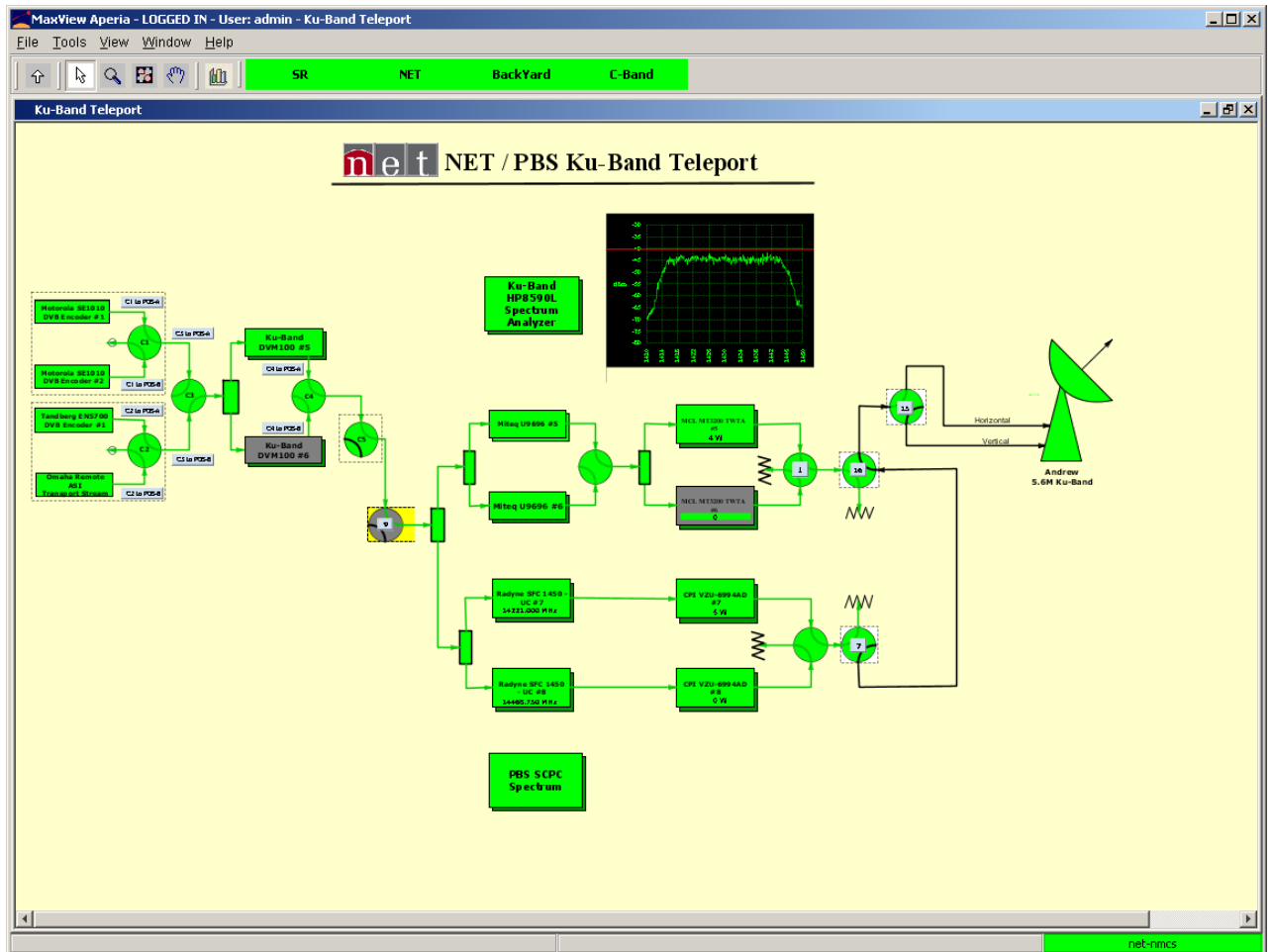

## Engineers Panel

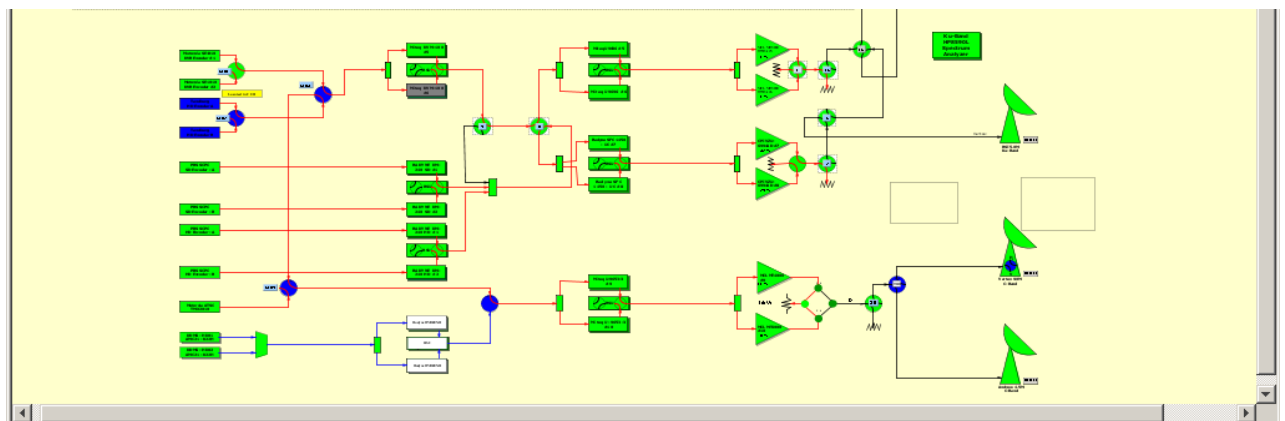

## NETC UPS and Facilities

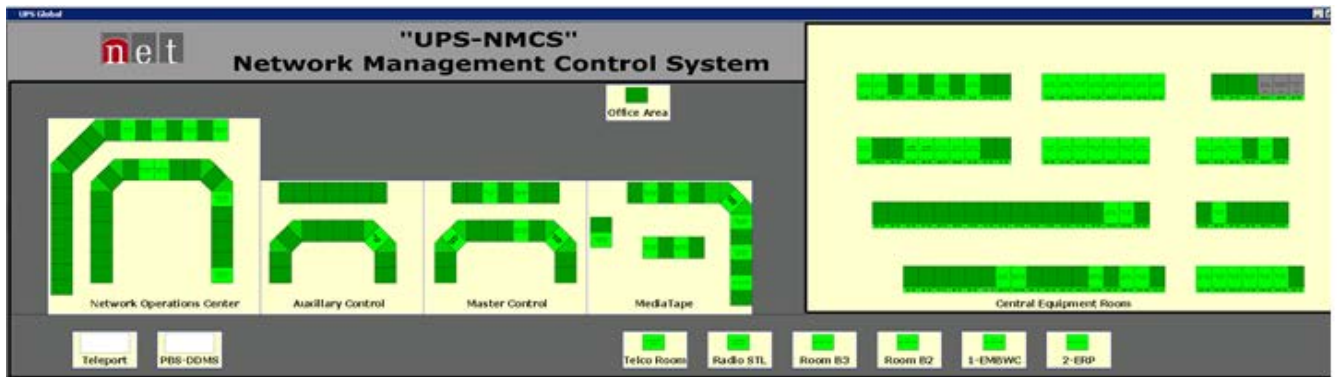

## Equipment Device Type Panels

### UPS

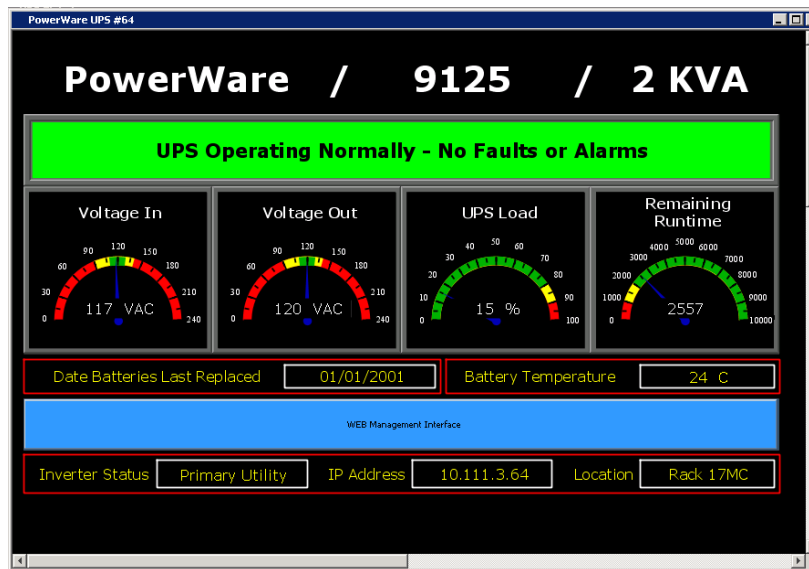

### High Power Amplifier

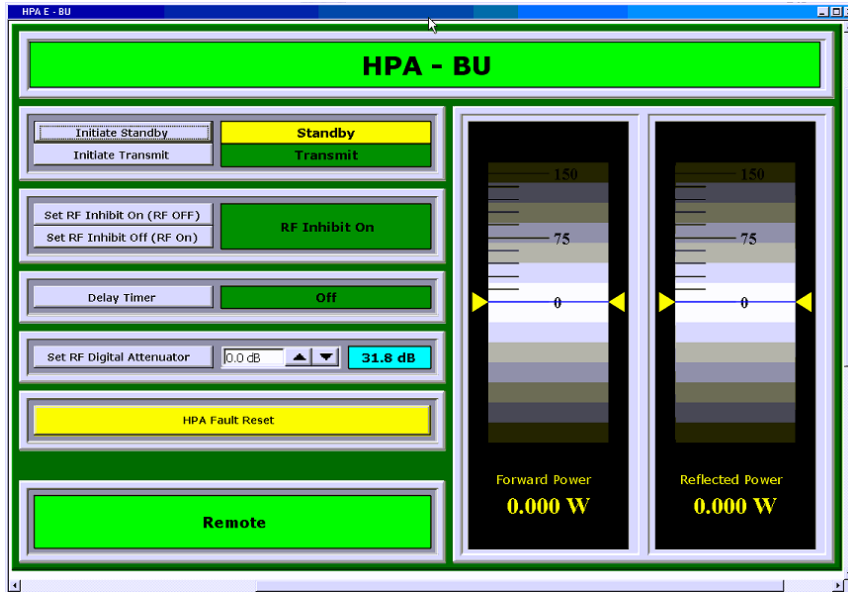

Antenna Controller

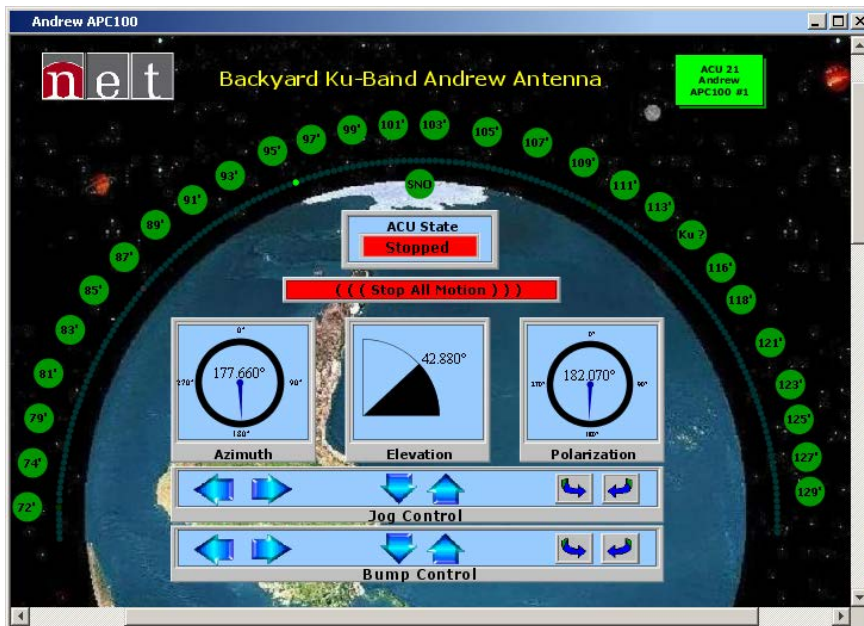

RF Upconverter





### Spectrum Analyzer

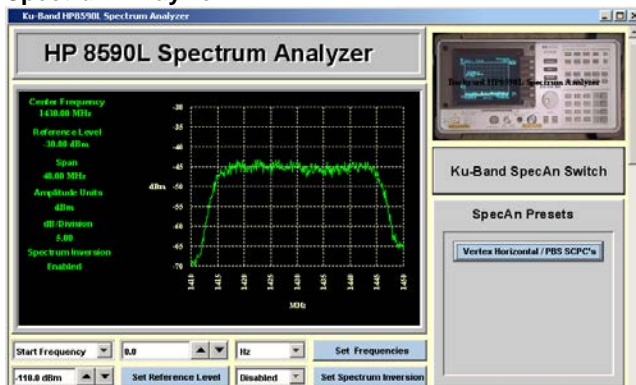

## D. PROJECT REQUIREMENTS

NETC intends to replace the existing NMCS with a system which will be integrated in parallel to the existing system allowing for no disruption of services or capabilities. The expansion of the NMCS into new areas will require installation, integration, and implementation of new and existing equipment and infrastructure, including running and terminating of a variety of cables and connectors. Adherence to NETC engineering practices and policies will be enforced (see Exhibit A). NETC seeks the following capabilities. Bidders shall indicate which capabilities are existing, in development, and will be developed to suite NETC's needs. (See Attachment 1)

1. The NMCS bid shall provide the ability to control and monitor the NETC NMCS systems via Virtual Private Network (VPN) using Standard Ethernet Internet Protocols, and a mechanism for backup monitor and control capabilities over dial up telephone when terrestrial IP connectivity is not available. The NMCS shall provide monitor and control capabilities whether that be alternate connectivity or a disparate system.
2. The NMCS bid shall provide the ability to communicate with remote devices over dial up telephone modems, direct connection and Ethernet IP.
3. The NMCS bid shall provide the ability for simultaneous control and monitoring from all or multiple workstations, by single and multiple operators connecting to similar or divergent NMCS systems.
4. The NMCS components bid shall provide the ability to be addressable using standard IPV4 addressing, and have the ability to be run locally and remotely.
5. The NMCS bid shall provide the ability of executing simultaneous commands or instructions to multiple remote devices at multiple diverse sites.
6. The NMCS bid shall provide the ability to execute preprogrammed events at specified times and/or in response to external triggers which may or may not be tied to automation events using synchronized time clock and/or GPI/GPO, serial, or ethernet interfaces.
7. The NMCS bid should have an open architecture protocol to allow for integration with existing and future third party systems.
8. The NMCS bid shall be capable of generating reports showing all commands issued, alarm and fault status, and system configurations. Reporting mechanism shall be capable of logging and reporting of system, service level, and device specific events.
9. The NMCS bid shall have provisions for redundancy, for both hardware and software systems.
10. The NMCS bid shall specify operating system software and versions for all software including third party software. Any server, terminal, workstation, or peripheral software required but not included shall be specified.
11. The NMCS bid should state any special "value added" features such as self-diagnostics, virtualization, accessibility, etc...
12. The NMCS bid should be capable of interoperability with other systems. These systems should be specified, e.g. automation, machine control, GPI/GPO, matrix routers, tally, etc...
13. The levels of technical and operational support shall be specified for the NMCS bid.
14. The NMCS bid shall have all system single-points-of-failure clearly indicated in the bid response.
15. A clearly defined list of proprietary and off-the-shelf technology for the NMCS bid shall be submitted for all hardware and software.
16. The NMCS bid shall have provisions for secure access, and customizable rights and permissions for all users of the system and be capable of supporting single sign-on through authentication.
17. The NMCS bid shall be scalable, capable of being upgraded and expanded due to improvements and/or enhancements to the infrastructure of the NETC system and/or systems capabilities.
18. The NMCS bid shall be capable of executing automated workflows related to equipment failovers, conditional variables, and backup solutions.

19. The NMCS bid shall be capable of issuing alarms relative to equipment and environment status viewable by all users, and have the capabilities for multiple alarm monitoring and masking options. Alarms must be able to be propagated to the top most level.
20. The NMCS bid should be capable of monitoring and controlling external or internal tally systems viewable within the system and on connected multiviewers, including the support for under monitor displays (UMD).
21. The NMCS bid shall be capable and compatible with common network security protocols to protect connections to the system that involve multiple VLANs in accordance with NETC Information Security Policies, Standards and Procedures.
22. The NMCS bid shall be capable of monitoring by exception with industry and user defined parameters, and user-defined graphic views/dashboards and pop-up alerts.
23. The NMCS bid shall have the capability to filter and notify multiple users or groups via email and SMS or MMS messaging of any alarm conditions at any of the locations. The ability to activate external audio and or visual alarms via GPI or other protocol should also be part of the system.
24. All device drivers that are not fully pointed drivers, allowing for all parameters as designed by the manufacturer, shall be indicated.
25. The NMCS bid shall have the ability to create custom panels, layouts and views made up from any and all elements within the system.
26. All cabling shall conform to NETC cable specifications\* and industry standard best practices. (See Exhibit A)
27. The NMCS bid shall provide detailed approaches addressing cyber security concerns including but not limited to architecture design, prevention, detection and response, and security audit.
28. The NMCS bid should be capable to recall system settings such as equipment setup, signal routes, router mnemonics and UMD settings for quick and easy deployments of applicable systems and/or equipment.

**E. BUSINESS REQUIREMENTS**

These are the minimum business requirements. A full explanation of all specifications for system bid shall be submitted in order to evaluate the bid responses and to determine the best value in function and price.

1. The NMCS bid shall specify any and all equipment required but not included in the RFP response. Projected cost for specified hardware, software, licenses, drivers, and any other equipment needed for the NMCS shall be specified in detail.
2. The NMCS bid shall have provisions for future expandability. Projected cost for system expandability concerning hardware, software, licenses, device drivers, and any other equipment needed for expansion shall be specified in detail including required steps.
3. The NMCS bid shall have provisions for a tiered support contract. Technical support shall be in the form of documentation, on-line, telephone, and/or in person on-site. Levels of support shall be specified in detail including limitations and liabilities.
4. The NMCS bid shall have provisions for system training at all levels. Training options shall include price per person, including all associated expenses for factory and/or on-site training. Training options should remain in effect during the entire time that the NMCS is under a support contract.
5. The NMCS bid shall have provisions for warranty coverage of all hardware supplied with the system including third party hardware, with provisions for extending warranty coverage.
6. All items requested in this RFP shall be supplied by a single contractor. All items shall integrate into a complete NMCS.
7. The bidder awarded the contract shall coordinate and work with the NETC NMCS Project Manager to create and develop a timeline for planning, installation, implementation, integration, configuration, and testing of the system or systems in all aspects of this contract prior to deployment.

8. NETC intends to replace the existing NMCS with the NMCS bid and further extend the NMCS bid to other listed technical functional areas. The NMCS bid shall monitor and control all devices that are part of this RFP, and support technology advancement and industry standards change.
9. The NMCS bid shall be integrated with NETC's Network Nebraska's terrestrial delivery network, University of Nebraska-Lincoln regional networks, NETC's virtual systems and multiple VLAN environments in accordance with NETC Information Security Policies, Standards and Procedures.
10. The NMCS bid shall have high availability, be able to automatically reconnect all devices, recall latest settings, retain latest captured status and regain control functions after power and /or network outages.
11. The NMCS bid shall be media and hardware agnostic

## **F. TECHNICAL REQUIREMENTS**

Below is a list of the minimum technical requirements for this RFP. A full explanation of all specifications for the system bid shall be submitted on Attachment 1.

### **1.0 Provide NMCS as Specified for NETC Transmission Systems and Remote Transmission sites.**

- 1.1.0 The NMCS specified shall provide the ability to control and monitor the NETC Television and Radio Broadcast Transmission Sites (Exhibit B). The NMCS should be able to control and monitor all existing and future equipment for the NETC Television and Radio Broadcast Transmission Sites (Exhibit C).
  - 1.1.1 The NMCS bid should be able to control and monitor all existing and future equipment for the NETC Television and Radio Broadcast Transmission Site KUON - Mead (Exhibit D).
  - 1.1.2 The NMCS bid should be able to control and monitor all existing and future equipment for the NETC Television and Radio Broadcast Transmission Site KHNE - Giltner (Exhibit E).
  - 1.1.3 The NMCS bid should be able to control and monitor all existing and future equipment for the NETC Television and Radio Broadcast Transmission Site KLNE - Atlanta (Exhibit F).
  - 1.1.4 The NMCS bid should be able to control and monitor all existing and future equipment for the NETC Television and Radio Broadcast Transmission Site KMNE - Bassett (Exhibit G).
  - 1.1.5 The NMCS bid should be able to control and monitor all existing and future equipment for the NETC Television and Radio Broadcast Transmission Site KPNE - Sutherland (Exhibit H).
  - 1.1.6 The NMCS bid should be able to control and monitor all existing and future equipment for the NETC Television and Radio Broadcast Transmission Site KRNE - Merriman (Exhibit J).
  - 1.1.7 The NMCS bid should be able to control and monitor all existing and future equipment for the NETC Television and Radio Broadcast Transmission Site KTNE - Angora (Exhibit K).
  - 1.1.8 The NMCS bid should be able to control and monitor all existing and future equipment for the NETC Television and Radio Broadcast Transmission Site KXNE - Carol (Exhibit L).
  - 1.1.9 The NMCS bid should be able to control and monitor all existing and future equipment for the NETC Television and Radio Broadcast Transmission Site KYNE - Omaha (Exhibit M).
  - 1.1.10 The NMCS bid should be able to control and monitor all existing and future equipment for the NETC Television and Radio Broadcast Transmission Site KUCV - Hallam (Exhibit N).
- 1.2.0 The NMCS bid shall have the ability to communicate with transmission equipment via serial RS232, RS422, and RS485 protocol. Bidder should specify exactly how serial communications will be established, administered, maintained, and operated.
- 1.3.0 The NMCS bid shall have the ability to communicate with transmission equipment via IP, TCP, UDP, HTTP, SNMP, FTP, Telnet and Networked Media Open Specifications protocols. Bidder should specify exactly how ethernet communications will be established, administered, maintained, and operated.
- 1.4.0 The NMCS bid shall have the ability to communicate with transmission equipment GPI and GPO interfaces. Bidder should specify exactly how parallel discrete GPI and GPO communications will be established,

- administered, maintained, and operated. The proposed system shall be able to support single and multiple bit drivers for alarm, status, and command functions as provided by discrete connections.
- 1.5.0 The NMCS bid shall have the ability to display analog measurements from direct connection to transmission equipment providing analog contacts. Bidder should specify exactly how analog measurements will be established, administered, maintained, and operated. The proposed system should be able to support drivers for analog measurements of percentage, amps, milliamps, micro amps, degrees-Fahrenheit, volts, kilovolts, psi, ratio, threshold, and watts as provided by discrete analog connections.
  - 1.6.0 The NMCS bid shall be able to communicate with the Harris Platinum ATSC high power television transmitter via SNMP and HTTP protocols, providing direct monitor and control via SNMP, and access to the integrated browser interface via http.
  - 1.7.0 The NMCS bid shall be able to communicate with the Harris Sigma CD ATSC high power television transmitter via discrete parallel connections, providing direct monitor and control via GPI, GPO, and analog interfaces.
  - 1.8.0 The NMCS bid shall be able to communicate with the Thales DCX Millennium ATSC high power television transmitter via multiple serial connections, providing direct monitor and control.
  - 1.8.1 The NMCS bid shall be able to communicate with the Thales ADAPT DTV Exciter via RS232 serial connections, providing direct monitor and control.
  - 1.8.2 The NMCS bid shall be able to communicate with the Comark Exact-ATSC Exciter via ethernet connections, providing direct SNMP monitor and control.
  - 1.9.0 The NMCS bid shall be able to communicate with the GatesAir Maxiva ATSC high power television transmitter via SNMP and HTTP protocols, providing direct monitor and control via SNMP, and access to the integrated browser interface via http.
  - 1.10.0 The NMCS bid shall be able to communicate with the Nautel NV5, NV20, and NC30 high power FM radio transmitter via SNMP and HTTP protocols, providing direct monitor and control via SNMP, and access to the integrated browser interface via http.
  - 1.11.0 The NMCS bid should be able to communicate with the Belar FMHD-1, FM modulation monitor via SNMP and HTTP protocols, providing direct monitor and control via SNMP, and access to the integrated browser interface via http.
  - 1.12.0 The NMCS bid should be able to communicate with the K-Tech DVM-150E DTV Demodulator/Decoder via SNMP and proprietary ethernet, providing direct monitor and control via SNMP and the Ktech proprietary GUI.
  - 1.13.0 The NMCS bid should be able to communicate with the K-Tech DCC-150E 8VSB DTV digital processor via SNMP and proprietary ethernet, providing direct monitor and control via SNMP and the Ktech proprietary GUI.
  - 1.14.0 The NMCS bid should be able to communicate with the K-Tech FRQ-200 ASI-to-310 converter via SNMP and proprietary ethernet, providing direct monitor and control via SNMP and the Ktech proprietary GUI.
  - 1.15.0 The NMCS bid should be able to communicate with the Evertz 7880IP ASI-to-IP converter via SNMP and proprietary Evertz VistaLink ethernet, providing direct monitor and control via SNMP and the Evertz VistaLink proprietary GUI.
  - 1.16.0 The NMCS bid shall be able to communicate with the Motorola DSR4410 Integrated Receiver Decoder via SNMP, providing direct monitor and control
  - 1.17.0 The NMCS bid shall be able to communicate with the Sencore 3187A Modular Receiver Decoder via SNMP and HTTP protocols, providing direct monitor and control via SNMP, and access to the integrated browser interface via http.
  - 1.18.0 The NMCS bid shall be able to communicate with the Sencore 3187B Modular Receiver Decoder via SNMP and HTTP protocols, providing direct monitor and control via SNMP, and access to the integrated browser interface via http.
  - 1.19.0 The NMCS bid shall be able to communicate with the Sencore MRD4400 Modular Receiver Decoder via SNMP and HTTP protocols, providing direct monitor and control via SNMP, and access to the integrated browser interface via http.

- 1.20.0 The NMCS bid shall be able to communicate with the Evertz X9504 digital baseband routing switcher via GVG TenXL RS232 and RS422 serial protocols, providing direct monitor and control.
- 1.21.0 The NMCS bid shall be able to communicate with the Videotek RS12A analog audio/video baseband routing switcher via GVG Performer ASCII RS232 and RS422 serial protocol, providing direct monitor and control.
- 1.22.0 The NMCS bid shall be able to communicate with the Videotek RS-12 MPEG digital baseband routing switcher via GVG Performer ASCII RS232 and RS422 serial protocols, providing direct monitor and control.
- 1.23.0 The NMCS bid should be able to communicate with the Sage Digital Endec EAS Encoder/Decoder Model 3644 via 10/100 Base-T LAN protocol, providing direct monitor and control and access to the integrated browser interface via http.
- 1.24.0 The NMCS bid shall be able to communicate with the Best Power Axxium 2000 UPS's via SNMP and HTTP protocol, providing direct monitor and control via SNMP, and access to the integrated browser interface via http.
- 1.25.0 The NMCS bid shall be able to communicate with the APC 2000 UPS's via SNMP and HTTP protocol, providing direct monitor and control via SNMP, and access to the integrated browser interface via http.
- 1.26.0 The NMCS bid should be able to communicate with the Xytronix Research & Design Control by Web X310 and X332 products via SNMP and HTTL protocol, providing direct monitor and control via SNMP, and access to the integrated browser interface via http.
- 1.27.0 The NMCS bid should be able to communicate with the EECI (Electronic Energy Control, Inc.) ADC-16 analog to digital converter via serial protocol, providing direct monitor and control.
- 1.28.0 The NMCS bid should be able to communicate with the HVAC systems in place at the remote transmission sites, providing monitoring and limited control where applicable.
- 1.29.0 The NMCS bid should be able to communicate with the electrical generator systems in place at the remote transmission sites, providing direct monitoring.
- 1.30.0 The NMCS bid should be able to communicate with the tower lighting systems in place at the remote transmission sites, providing direct monitoring.

## **2.0 Provide NMCS as Specified for NETC Satellite Teleport Systems.**

- 2.1.0 The NMCS bid shall provide the ability to control and monitor the NETC Ku-Band and C-band Satellite Teleport Systems. The NMCS should be able to control and monitor all existing and future equipment for the NETC Ku-Band and C-band Satellite Teleport Systems.
- 2.2.0 The NMCS bid shall have the ability to communicate with teleport equipment via serial RS232, RS422, and RS485 protocol. Bidder should specify exactly how serial communications will be established, administered, maintained, and operated.
- 2.3.0 The NMCS bid shall have the ability to communicate with teleport equipment via IP, TCP, UDP, HTTP, SNMP, FTP, Telnet and Networked Media Open Specifications protocols. Bidder should specify exactly how ethernet communications will be established, administered, maintained, and operated.
- 2.4.0 The NMCS bid shall have the ability to communicate with teleport equipment GPI and GPO interfaces. Bidder should specify exactly how parallel discrete GPI and GPO communications will be established, administered, maintained, and operated. The proposed system shall be able to support single and multiple bit drivers for alarm, status, and command functions as provided by discrete connections.
- 2.5.0 The NMCS bid shall have the ability to display analog measurements from direct connection to teleport equipment providing analog contacts. Bidder should specify exactly how analog measurements will be established, administered, maintained, and operated. The proposed system should be able to support drivers for analog measurements of percentage, amps, milliamps, micro amps, degrees-Fahrenheit, volts, kilovolts, psi, ratio, threshold, and watts as provided by discrete analog connections.
- 2.6.0 The NMCS bid should be able to communicate with the Vertex 7134 Antenna Controller via serial protocol, providing direct monitor and control.
- 2.7.0 The NMCS bid shall be able to communicate with the Andrew APC100 Antenna Controller via serial protocol, providing direct monitor and control.
- 2.8.0 The NMCS bid shall be able to communicate with the Research Concepts RC1000 Antenna Controller via serial protocol, providing direct monitor and control.
- 2.9.0 The NMCS bid shall be able to communicate with the Research Concepts RC2000 Antenna Controller via serial protocol, providing direct monitor and control.
- 2.10.0 The NMCS bid shall be able to communicate with the Miteq/MCL MT3200 Ku-Band High Power Amplifier via serial protocol, providing direct monitor and control.
- 2.11.0 The NMCS bid shall be able to communicate with the Miteq/MCL MT4000 Ku-Band High Power Amplifier via serial protocol, providing direct monitor and control.
- 2.11.1 The NMCS bid shall be able to communicate with the Miteq/MCL PSU 1:4 HPA protection Switch via serial and HTTP protocol, providing direct monitor and control via serial communications, and access to the integrated browser interface via http.
- 2.12.0 The NMCS bid shall be able to communicate with the Miteq/MCL MT4000 C-Band High Power Amplifier via serial protocol, providing direct monitor and control.
- 2.12.1 The NMCS bid shall be able to communicate with the Miteq/MCL MXC-VPC Variable Phase Combiner via serial protocol, providing direct monitor and control.
- 2.13.0 The NMCS bid shall be able to communicate with the CPI VZU-6994AD Ku-Band High Power Amplifier via serial protocol, providing direct monitor and control.
- 2.13.1 The NMCS bid shall be able to communicate with the CPI VZU-CMPA 1:1 Redundancy Switch via serial protocol, providing direct monitor and control.
- 2.14.0 The NMCS bid shall be able to communicate with the Miteq/MCL U-9653-3 C-Band Upconverter via serial protocol, providing direct monitor and control.

- 2.15.0 The NMCS bid shall be able to communicate with the Miteq/MCL U-9696 Ku-Band Upconverter via serial protocol, providing direct monitor and control.
- 2.16.0 The NMCS bid shall be able to communicate with the Miteq/MCL U-9656-6-1K Ku-Band Upconverter via Serial, and SNMP protocol, providing direct monitor and control.
- 2.16.1 The NMCS bid shall be able to communicate with the Miteq/MCL NSU 1:4 Redundancy Switch via Serial and SNMP protocol, providing direct monitor and control.
- 2.17.0 The NMCS bid shall be able to communicate with the Radyne SFC-1450 Ku-Band Upconverter via Serial protocol, providing direct monitor and control.
- 2.18.0 The NMCS bid shall be able to communicate with the Newtec M6100 DVBS Modulator via SNMP and HTTP protocol, providing direct monitor and control via SNMP communications, and access to the integrated browser interface via http.
- 2.18.1 The NMCS bid shall be able to communicate with the Newtec AZ202 1:7 Protection Switch via SNMP and HTTP protocol, providing direct monitor and control via SNMP communications, and access to the integrated browser interface via http.
- 2.19.0 The NMCS bid shall be able to communicate with the Miteq DVM100 DVBS Modulator via Serial, SNMP and HTTP protocols, providing direct monitor and control via Serial or SNMP communications, and access to the integrated browser interface via http.
- 2.20.0 The NMCS bid shall be able to communicate with the Radyne DM240 DVBS Modulator via Serial protocol, providing direct monitor and control.
- 2.20.1 The NMCS bid shall be able to communicate with the Radyne DM240 1:1 Redundancy Switch via Serial protocol, providing direct monitor and control.
- 2.21.0 The NMCS bid shall be able to communicate with the Miteq RSU 1:1 Redundancy Switch via serial protocol, providing direct monitor and control.
- 2.22.0 The NMCS bid should provide the ability to control and monitor the Adtec Digital EN210 Multi-codec Encoder via GPIO, serial, IP and/or other means as allowed by the manufacturer.
- 2.23.0 The NMCS bid should be able to communicate with the Agilent E-Series Spectrum Analyzer via GPIB protocol, providing direct monitor and control.
- 2.24.0 The NMCS bid shall be able to communicate with the Hewlett Packard 8595E Spectrum Analyzer via Serial protocol, providing direct monitor and control.
- 2.25.0 The NMCS bid shall be able to communicate with the Hewlett Packard 8590L Spectrum Analyzer via Serial protocol, providing direct monitor and control.
- 2.26.0 The NMCS bid shall be able to communicate with the Quintech SRR-2150 16x1 L-Band Routing Switcher via SNMP protocol, providing direct monitor and control.
- 2.27.0 The NMCS bid shall be able to communicate with the Standard Communications MT-930 Satellite Receiver via Serial protocol, providing direct monitor and control.
- 2.28.0 The NMCS bid shall be able to communicate with the Sencore 3187A Modular Receiver Decoder via SNMP and HTTP protocols, providing direct monitor and control via SNMP, and access to the integrated browser interface via http.
- 2.29.0 The NMCS bid shall be able to communicate with the Sencore 3187B Modular Receiver Decoder via SNMP and HTTP protocols, providing direct monitor and control via SNMP, and access to the integrated browser interface via http.
- 2.30.0 The NMCS bid should be able to communicate with the Xytronix Research & Design Control by Web X310 and X332 products via SNMP and HTTP protocol, providing direct monitor and control via SNMP, and access to the integrated browser interface via http.
- 2.31.0 The NMCS bid should be able to communicate with the EECl (Electronic Energy Control, Inc.) ADC-16 analog to digital converter via serial protocol, providing direct monitor and control.



### **3.0 Provide NMCS as Specified for NETC Television and Radio Facilities.**

- 3.1.0 The NMCS bid shall provide the ability to control and monitor the NETC Television and Radio Facilities.
- 3.2.0 The NMCS bid shall have the ability to communicate with facilities equipment via serial RS232, RS422, and RS485 protocol. Bid response should specify exactly how serial communications will be established, administered, maintained, and operated.
- 3.3.0 The NMCS bid shall have the ability to communicate with facilities equipment via IP, TCP, UDP, HTTP, SNMP, FTP, Telnet and Networked Media Open Specifications protocols. Bidder should specify exactly how ethernet communications will be established, administered, maintained, and operated.
- 3.4.0 The NMCS bid shall have the ability to communicate with facilities equipment GPI and GPO interfaces. Bidder should specify exactly how parallel discrete GPI and GPO communications will be established, administered, maintained, and operated. The proposed system shall be able to support single and multiple bit drivers for alarm, status, and command functions as provided by discrete connections.
- 3.5.0 The NMCS bid shall have the ability to display analog measurements from direct connection to facilities equipment providing analog contacts. Bidder should specify exactly how analog measurements will be established, administered, maintained, and operated. The proposed system should be able to support drivers for analog measurements of percentage, amps, milliamps, micro amps, degrees-Fahrenheit, volts, kilovolts, psi, ratio, threshold, and watts as provided by discrete analog connections.
- 3.6.0 The NMCS bid should be able to communicate with the Lieberts HVAC systems via SNMP protocol, providing direct monitor and control.
- 3.7.0 The NMCS bid should be able to communicate with the Cummins/Onan generators, providing direct monitoring.
- 3.8.0 The bid shall be able to communicate with various models of APC UPS systems via SNMP protocol, providing direct monitor and control, and access to the integrated browser interface via http.
- 3.9.0 The NMCS bid shall be able to communicate with various models of Best Power UPS systems via SNMP protocol, providing direct monitor and control, and access to the integrated browser interface via http.
- 3.10.0 The NMCS bid shall be able to communicate with various models of Powerware UPS systems via SNMP protocol, providing direct monitor and control, and access to the integrated browser interface via http.
- 3.11.0 The NMCS bid should be able to communicate with the Pelco DX4800 security camera systems, providing direct monitor and control. NETC is looking to modernize its existing outdated analog security camera system, bidder should provide a list of specified solution currently supported security camera systems.
- 3.12.0 The NMCS bid should be able to communicate with the HID security door system, providing direct monitor and control.
- 3.13.0 The NMCS bid should be able to communicate with the Vesda Fire detection systems, providing direct monitoring.

**4.0 Provide NMCS as Specified for NETC Television and Radio Terminal Equipment and Production Matrix Routing Switcher Systems.**

- 4.1.0 The NMCS bid should have provisions for future expandability to provide control and monitoring of the NETC Television and Radio Terminal Equipment and Production Matrix Routing Switcher Systems. The future expandability provision should allow for control and monitoring of existing and future equipment for the NETC Television and Radio Terminal Equipment and Production Matrix Routing Switcher Systems.
- 4.2.0 The NMCS bid shall have the ability to communicate with terminal and routing switcher equipment via serial RS232, RS422, and RS485 protocol. Bidder should specify exactly how serial communications will be established, administered, maintained, and operated.
- 4.3.0 The NMCS bid shall have the ability to communicate with terminal and routing switcher equipment via IP, TCP, UDP, HTTP, SNMP, FTP, Telnet and Networked Media Open Specifications protocols. Bidder should specify exactly how ethernet communications will be established, administered, maintained, and operated.
- 4.4.0 The NMCS bid shall have the ability to communicate with terminal and routing switcher equipment GPI and GPO interfaces. Bidder should specify exactly how parallel discrete GPI and GPO communications will be established, administered, maintained, and operated. The proposed system shall be able to support single and multiple bit drivers for alarm, status, and command functions as provided by discrete connections.
- 4.5.0 The NMCS bid shall have the ability to display analog measurements from direct connection to terminal and routing switcher equipment providing analog contacts. Bidder should specify exactly how analog measurements will be established, administered, maintained, and operated. The proposed system should be able to support drivers for analog measurements of percentage, amps, milliamps, micro amps, degrees-Fahrenheit, volts, kilovolts, psi, ratio, threshold, and watts as provided by discrete analog connections.
- 4.6.0 The NMCS bid should be able to communicate with Evertz 7700FR and 7800FR Frames via SNMP and GPI/GPO communications, providing monitor and control of frame and module status.
- 4.7.0 The NMCS bid should be able to communicate with various Evertz 7700 and 7800 modules via ethernet communications, providing monitor and control utilizing SNMP, or access via Evertz Vistalink proprietary NMS.
- 4.8.0 The NMCS bid should be able to communicate with the Utah Scientific UTAH-300 analog matrix routing switcher.
- 4.9.0 The NMCS bid should be able to communicate with the Grass Valley Venus Wideband digital matrix routing switcher.
- 4.10.0 The NMCS bid should be able to communicate with the Imagine Communications Platinum VX 3G Digital matrix routing switcher.
- 4.11.0 The NMCS bid should be hardware and media agnostic, that is able to provide routing switcher control for the routing switchers referred to in section 4.8, 4.9, and 4.10. As well as IP based layer 2 and layer 3 ethernet switches which comply with Professional Media Over Managed IP Networks suite of standards such as SMPTE ST2022, and ST2110 .
- 4.11.1 The NMCS bid should be able to provide a routing switcher control system which should be capable of controlling the routing switchers through a series of mapping tables in order to create a "Hybrid" routing switcher made up of gateways, processors, and converters providing logical signal flow between systems and end-to-end service level events.
- 4.11.2 The NMCS bid should be able to provide a routing switcher control system which should be capable of controlling the routing switchers through both software and hardware panels. Panels should be capable of full X-Y switching, limited X-Y switching, and button-per-source switching.
- 4.11.3 The NMCS bid should be able to provide a routing switcher control system which should be capable of controlling the existing Grass Valley CP300 and CP328 hardware panels. Panels should be capable of full X-Y switching, limited X-Y switching, and button-per-source switching where applicable.

**5.0 Provide NMCS as Specified for NETC Television and Radio Master Control, Production Studios and Remote Systems.**

- 5.1.0 The NMCS bid should have provisions for future expandability to provide control and monitoring of the NETC Television and Radio Master Control, Production Studios and Remote Systems. The future expandability provision should allow for control and monitoring of existing and future equipment for the NETC Television and Radio Remote Systems.
- 5.2.0 The NMCS bid shall have the ability to communicate with Master Control, Production Studios and Remote Systems equipment via serial RS232, RS422, and RS485 protocol. Bidder should specify exactly how serial communications will be established, administered, maintained, and operated.
- 5.3.0 The NMCS bid shall have the ability to communicate with Master Control, Production Studios and Remote Systems equipment via IP, TCP, UDP, HTTP, SNMP, FTP, Telnet and Networked Media Open Specifications protocols. Bidder should specify exactly how ethernet communications and IP protocols will be established, administered, maintained, and operated.
- 5.4.0 The NMCS bid shall have the ability to communicate with Master Control, Production Studios and Remote Systems equipment GPI and GPO interfaces. Bidder should specify exactly how parallel discrete GPI and GPO communications will be established, administered, maintained, and operated. The proposed system shall be able to support single and multiple bit drivers for alarm, status, and command functions as provided by discrete connections.
- 5.5.0 The NMCS bid shall have the ability to display analog measurements from direct connection to Master Control, Production Studios and Remote Systems equipment providing analog contacts. Bidder should specify exactly how analog measurements will be established, administered, maintained, and operated. The proposed system should be able to support drivers for analog measurements of percentage, amps, milliamps, micro amps, degrees-Fahrenheit, volts, kilovolts, psi, ratio, threshold, and watts as provided by discrete analog connections.
- 5.6.0 The NMCS bid should have the ability to respond to SNMP traps sent from the Imagine Communications Versio Integrated Video Server (Channel-in-a-box).
- 5.7.0 The NMCS bid should be able to communicate with the Sage Digital Endec EAS Encoder/Decoder Model 3644 via 10/100 Base-T LAN protocol, providing monitor and control and access to the integrated browser interface via http.
- 5.8.0 The NMCS bid should be able to communicate with the Euphonix System 5 Audio Mixing Console via EuCon/SNMP protocol, providing monitor and control.
- 5.9.0 The NMCS bid should be able to communicate with the Grass Valley Kayak HD and Karrera/K-Frame Vision Mixer, providing monitor and control.
- 5.10.0 The NMCS bid should be able to communicate with the Vizrt Treo Graphics System via SNMP protocol, providing monitor and control.
- 5.11.0 The NMCS bid should be able to communicate with the AVID Thunder Video Server System, providing monitor and control.
- 5.12.0 The NMCS bid should be able to communicate with the Grass Valley Summit K2 Video Server System, providing monitor and control.
- 5.13.0 The NMCS bid should be able to communicate with the EVS XT3 System via Truck Manager proprietary EVS protocol, providing monitor and control.
- 5.14.0 The NMCS bid should be able to communicate with the Harris Predator Multiviewer System via SNMP protocol, providing monitor and control.
- 5.15.0 The NMCS bid should be able to communicate with the Grass Valley Trinix NXT Multiviewer, providing monitor and control.
- 5.16.0 The NMCS bid should be able to communicate with the Bosch (RTS / Telex) Intercom System, providing monitor and control.

- 5.17.0 The NMCS bid should be able to communicate with the Grass Valley LDK3000 Camera System, providing monitor and control.
- 5.18.0 The NMCS bid should be able to communicate with the Grass Valley LDK80 and LDX86N Camera System, providing monitor and control.
- 5.19.0 The NMCS bid should be able to communicate with the AJA FS2 Frame Synchronizer System, providing monitor and control.
- 5.20.0 The NMCS bid should be able to communicate with the For-A FA-9500, 9520, and 505 Frame Synchronizer Systems, providing monitor and control.
- 5.21.0 The NMCS bid should be able to communicate with the For-A FVW5-00HS Telestrator via SNMP protocol, providing monitor and control.
- 5.22.0 The NMCS bid should be able to communicate with the Atomos Shogun Studio via serial RS422 and ethernet connection for using AMP protocol, providing monitor and control.
- 5.23.0 The NMCS system bid should be able to communicate with the ETC Express 48/96 Lighting Board System via DMX protocol, providing monitor and control.
- 5.24.0 The bid should be able to communicate with the Newtec Tricaster Model 460 and Model 8000 Vision Mixer via serial protocol, providing monitor and control.
- 5.25.0 The NMCS bid should be able to communicate with the Broadcast Pix Slate-HD Vision Mixer System via VDCP protocol, providing monitor and control.
- 5.26.0 The NMCS bid should be able to communicate with the Yamaha 02V96 Audio Mixing Console via MIDI protocol, providing monitor and control.
- 5.27.0 The NMCS bid should be able to communicate with the Image Video TSI3000 Tally System, providing monitor and control.
- 5.28.0 The NMCS bid should be able to communicate with the Tektronix SPG8000 Master Clock/Sync System, providing monitor and control.
- 5.29.0 The NMCS bid should be able to communicate with the Grass Valley Trinix Wideband digital matrix routing switcher.
- 5.29.1 The NMCS bid should be able to provide a routing switcher control system which should be capable of controlling the routing switchers through a series of mapping tables in order to create a "Hybrid" routing switcher made up of gateways, processors, and converters providing logical signal flow between systems and end-to-end service level events.
- 5.29.2 The NMCS bid should be able to provide a routing switcher control system which should be capable of controlling the routing switchers through both software and hardware panels. Panels should be capable of full X-Y switching, limited X-Y switching, and button-per-source switching.
- 5.29.3 The bid should be able to provide a routing switcher control system which should be capable of controlling the existing and additional Grass Valley CP300, CP330, CP328 and SXY hardware panels. Panels should be capable of full X-Y switching, limited X-Y switching, and button-per-source switching where applicable.
- 5.30.0 The NMCS bid should provide the ability to control and monitor the Broadcast Electronics' AudioVAULT system via GPIO, serial data (where applicable) and/or other means allowed by manufacturer. Bidder should specify exactly how communications will be established, administered, maintained, and operated.
- 5.31.0 The NMCS bid should provide the ability to control and monitor the Broadcast Electronics' AVFlex automation and playout system via GPIO, serial data (where applicable) and/or other means allowed by manufacturer. Bidder should specify exactly how communications will be established, administered, maintained, and operated.
- 5.32.0 The NMCS bid should provide the ability to control and monitor the Broadcast Tools Streaming Sentinel 4 via GPIO, SNMP, and access to the integrated browser interface via http, and/or other means allowed by

- manufacturer. Bidder should specify exactly how communications will be established, administered, maintained, and operated.
- 5.33.0 The NMCS bid should provide the ability to control and monitor the Broadcast Tools WVRC-8 Dial-up Remote Control System via GPIO, SNMP, and access to the integrated browser interface via http, and/or other means allowed by manufacturer. Bidder should specify exactly how communications will be established, administered, maintained, and operated.
- 5.34.0 The NMCS bid should provide the ability to control and monitor the International Datacasting Pro Audio EXP Satellite Receiver via GPIO, SNMP, and access to the integrated browser interface via http, and/or other means allowed by manufacturer. Bidder should specify exactly how communications will be established, administered, maintained, and operated.
- 5.35.0 The NMCS system bid should provide the ability to control and monitor the International Datacasting SR2000 Pro Satellite Receiver via GPIO, SNMP, and access to the integrated browser interface via http, and/or other means allowed by manufacturer. Bidder should specify exactly how communications will be established, administered, maintained, and operated.
- 5.36.0 The NMCS bid should provide the ability to control and monitor the Nautel HD Radio Importer Plus via GPIO, SNMP and/or other means allowed by manufacturer. Bidder should specify exactly how communications will be established, administered, maintained, and operated.
- 5.37.0 The NMCS bid should provide the ability to control and monitor the Nautel HD Radio Exporter Plus via GPIO, SNMP and/or other means allowed by manufacturer. Bidder should specify exactly how communications will be established, administered, maintained, and operated.
- 5.38.0 The NMCS bid should be able to communicate with the Sage Digital Endec EAS Encoder/Decoder Model 3644 via 10/100 Base-T LAN protocol, providing monitor and control, and access to the integrated browser interface via http.
- 5.39.0 The NMCS bid should provide the ability to control and monitor the Telos Pathfinder Routing Control Software Suite via GPIO, serial and/or other means allowed by manufacturer. Bidder should specify exactly how communications will be established, administered, maintained, and operated.
- 5.40.0 The NMCS bid should provide the ability to control and monitor the Telos ZIP/One IP Audio Link via GPIO, HTTP and/or other means allowed by manufacturer. Bidder should specify exactly how communications will be established, administered, maintained, and operated.
- 5.41.0 The NMCS bid should provide the ability to control and monitor the Moseley Startlink 9003Q Microwave STL via GPIO, serial and/or other means allowed by manufacturer. Bidder should specify exactly how communications will be established, administered, maintained, and operated.

**6.0 Provide NMCS as Specified for NETC Television and Radio Web Services and IT Networking Systems**

- 6.1.0 The NMCS bid should have provisions for future expandability to provide control and monitoring of the NETC Television and Radio Web Services and IT Networking Systems. The future expandability provision should allow for control and monitoring of existing and future equipment for the NETC Television and Radio Web Services and IT Networking Systems.
- 6.2.0 The NMCS bid shall have the ability to communicate with NETC Web Services and IT Networking Systems equipment via serial RS232, RS422, and RS485 protocol. Bidder should specify exactly how serial communications will be established, administered, maintained, and operated.
- 6.3.0 The NMCS bid shall have the ability to communicate with NETC Web Services and IT Networking Systems equipment via IP, TCP, UDP, HTTP, SNMP, FTP, Telnet and Networked Media Open Specifications protocols. Bidder should specify exactly how ethernet communications will be established, administered, maintained, and operated.
- 6.4.0 The NMCS bid shall have the ability to communicate with NETC Web Services and IT Networking Systems equipment GPI and GPO interfaces. Bidder should specify exactly how parallel discrete GPI and GPO communications will be established, administered, maintained, and operated. The proposed system should be able to support single and multiple bit drivers for alarm, status, and command functions as provided by discrete connections.
- 6.5.0 The NMCS bid shall have the ability to display analog measurements from direct connection to NETC Web Services and IT Networking Systems equipment providing analog contacts. Bidder should specify exactly how analog measurements will be established, administered, maintained, and operated. The proposed system should be able to support drivers for analog measurements of percentage, amps, milliamps, micro amps, degrees-Fahrenheit, volts, kilovolts, psi, ratio, threshold, and watts as provided by discrete analog connections.
- 6.6.0 The NMCS bid should be able to communicate with the Imagine Communications (Digital Rapids) Broadcast Manager Streaming Scheduler, providing monitor and control, and access to the integrated browser interface via http.
- 6.6.1 The NMCS bid should be able to communicate with the Imagine Communications (Digital Rapids) SelinoFlex Live and StreamZ Streaming Encoders, providing monitor and control, and access to the integrated browser interface via http.
- 6.7.0 The NMCS bid should be able to communicate with the NETC Nagios Core and Nagios Network Analyzer software systems, providing monitor and control for network infrastructure and alerting for servers, switches, applications and services.
- 6.8.0 The NMCS bid should be able to communicate with the NETC Solarwinds Network Analyzer software systems, providing monitor and control for network infrastructure.
- 6.9.0 The NMCS bid should be able to communicate with the NETC KACE enterprise systems inventory, ticketing system, providing intractability between the NMCS and the KACE system.
- 6.10.0 The NMCS bid should be able to communicate with the NETC Snort IPS (intrusion prevention system), providing intractability between the NMCS and the Snort system.

## **7.0 Provide NMCS as Specified for NETC Government Services Audio-Video Systems**

- 7.1.0 The NMCS bid should have provisions for future expandability to provide control and monitoring of the NETC Government Services Audio-Video Systems. The future expandability provision should allow for control and monitoring of existing and future equipment for the NETC Government Services Audio-Video Systems.
- 7.2.0 The NMCS bid shall have the ability to communicate with NETC Government Services Audio-Video Systems equipment via serial RS232, RS422, and RS485 protocol. Bidder should specify exactly how serial communications will be established, administered, maintained, and operated.
- 7.3.0 The NMCS bid shall have the ability to communicate with NETC Government Services Audio-Video Systems equipment via IP, TCP, UDP, HTTP, SNMP, FTP, Telnet and Networked Media Open Specifications protocols. Bidder should specify exactly how ethernet communications will be established, administered, maintained, and operated.
- 7.4.0 The NMCS bid shall have the ability to communicate with NETC Government Services Audio-Video Systems equipment GPI and GPO interfaces. Bidder should specify exactly how parallel discrete GPI and GPO communications will be established, administered, maintained, and operated. The proposed system should be able to support single and multiple bit drivers for alarm, status, and command functions as provided by discrete connections.
- 7.5.0 The NMCS bid shall have the ability to display analog measurements from direct connection to NETC Government Services Audio-Video Systems equipment providing analog contacts. Bidder should specify exactly how analog measurements will be established, administered, maintained, and operated. The proposed system should be able to support drivers for analog measurements of percentage, amps, milliamps, micro amps, degrees-Fahrenheit, volts, kilovolts, psi, ratio, threshold, and watts as provided by discrete analog connections.
- 7.6.0 The NMCS bid should be able to communicate with the Crestron Pro2 Controller via SNMP, providing monitor and control.
- 7.7.0 The NMCS system bid should be able to communicate with the Yamaha DME 64/24 Audio Processor via ethernet and/or serial protocol, providing monitor and control.
- 7.8.0 The NMCS bid should be able to communicate with Evertz 7700FR and 7800FR Frames via SNMP and GPI/GPO communications, providing monitor and control of frame and module status.
- 7.9.0 The NMCS bid should be able to communicate with various Evertz 7700 and 7800 modules via ethernet communications, providing monitor and control utilizing SNMP, or access via Evertz Vistalink proprietary NMS.

## **VI. PROJECT PLANNING AND MANAGEMENT**

The NMCS project continues to support an innovative, modular, scalable, secure open platform, future ready and phased approach. The NETC Chief Technology Officer (CTO) and NETC NMCS Project Manager will have ultimate authority over the NMCS project with the NETC project manager being the single point of contact for NETC.

The bidder shall establish a primary contact person within their proposal, including the contact's name, address, phone and fax numbers, and email address.

The bidder shall provide project implementation plan including but not limited to installation, integration, and phased approach timelines with milestones for completing the project.

The awarded contractor will schedule a conference call within ten (10) working days of contract finalization with the NETC NMCS Project Manager and designees to set a regular weekly conference call which will take place for the duration of the contract. The contractor will work with NETC NMCS Project Manager to establish a workable timeline for planning, installation, implementation, integration, configuration, and testing of the system or systems deployed.

The bidder should present a detailed description of its proposed approach to the management of this project, and a block diagram describing the NMCS system architecture they are proposing.

All service shall be coordinated in advance with the NETC project manager during normal business hours, Monday through Friday, 8:30 AM through 4:30 PM CST.

Precaution shall be taken by the contractor and it's designees to prevent any interruption of NETC broadcast and non-broadcast services. All installation, integration and implementation work to be performed will be coordinated with the NETC NMCS Project Manager who will coordinate with NET television and radio operations, content creation and production departments.

The contractor must identify any specific professionals and/or subcontractors who will work on the project if their company is awarded the bid resulting from the Request for Proposal.

A copy of the final inspection report, test results, services performed, and recommended improvements is to be left on site with NETC NMCS Project Manager or designee upon completion of service and will be submitted with the final invoice for each phase.

The bidder will provide complete documentation of the NMCS system deployed (manuals, drawings, schematics, charts, graphs, lists, etc....) software copies are acceptable.

### **A. EVALUATE CURRENT PROJECT ENVIRONMENT**

The awarded contractor will coordinate and schedule an on-site visit to evaluate the project environment and work with NETC NMCS Project Manager and designees to determine the best methods and mechanisms for installation, implementation, integration, configuration, and testing of the systems deployed.

### **B. POST IMPLEMENTATION SUPPORT**

The awarded contractor will provide project follow-up for five (5) years including quarterly scheduled phone calls and an itemized list of ongoing action items and issues and their planned resolutions.

Support will also be provided as outlined in section E.3.

### **C. DELIVERABLES**

Bidder shall provide all hardware and/or software and/or services which will include but not be limited to the entire systems as listed in this RFP, and any upgrades, changes, additions or deletions for the NMCS as indicated for the NETC facility or facilities.

Contractor shall respond to all non-emergency service requests or questions within forty-eight (48) hours after receiving a phone call, email, or opened support ticket.

The Contractor will provide emergency service as requested. Response time via E mail, telephone or fax for emergency or requested service will not exceed twelve (12) hours after receiving a phone call, email, or opened support ticket..



The Contractor shall provide system information or communication via E mail and/or telephone as requested by the NETC NMCS Project Manager or designee within forty eight (48) hours after receiving a phone call, email, or opened support ticket..

A copy of the final inspection report, test results, services performed, and recommended improvements is to be left on site with NETC NMCS Project Manager or designee upon completion of service.

The Bidder shall establish a primary contact person within their proposal, including the contact's name, address, phone and fax numbers, and email address.

All service shall be coordinated in advance with NETC NMCS Project Manager or designee during normal business hours, Monday through Friday, 8:30 AM through 4:30 PM CST.

The contractor will work with NETC NMCS Project Manager to finalize a "Proof of Performance Acceptance Checklist" for each phase of the project. This will be used during installation, implementation, integration, configuration, and testing of the system or systems deployed. Once the "Proof of Performance Acceptance Checklist" has been signed off and accepted, the remaining retainage for that phase of the project will be released for payment.

All equipment warranties will not take effect until the equipment is unboxed, uncrated, or opened for installation. Any equipment failures which occur during installation will be covered under the manufactures warranty.

Support contract and any Service Level Agreement (SLA) will not take effect until commissioning has taken place and "Proof of Performance Checklist" has been completed.

## VII. PROPOSAL INSTRUCTIONS

This section documents the requirements that should be met by bidders in preparing the Technical and Cost Proposal. Bidders should identify the subdivisions of "Project Description and Scope of Work" clearly in their proposals; failure to do so may result in disqualification. Failure to respond to a specific requirement may be the basis for elimination from consideration during the State's comparative evaluation.

Proposals are due by the date and time shown in the Schedule of Events. Content requirements for the Technical and Cost Proposal are presented separately in the following subdivisions; format and order:

### A. PROPOSAL SUBMISSION

#### 1. REQUEST FOR PROPOSAL FORM

By signing the "RFP for Contractual Services" form, the bidder guarantees compliance with the provisions stated in this RFP, agrees to the Terms and Conditions stated in this RFP unless otherwise agreed to, and certifies bidder maintains a drug free work place environment.

The RFP for Contractual Services form must be signed using an indelible method (not electronically) and returned per the schedule of events in order to be considered for an award.

Sealed proposals must be received in the State Purchasing Bureau by the date and time of the proposal opening per the Schedule of Events. No late proposals will be accepted. No electronic, e-mail, fax, voice, or telephone proposals will be accepted.

It is the responsibility of the bidder to check the website for all information relevant to this solicitation to include addenda and/or amendments issued prior to the opening date. Website address is as follows: <http://das.nebraska.gov/materiel/purchasing.html>

Further, Sections II through VII must be completed and returned with the proposal response.

#### 2. CORPORATE OVERVIEW (~~Delete Corporate Overview if Cost Only~~)

The Corporate Overview section of the Technical Proposal should consist of the following subdivisions:

##### a. BIDDER IDENTIFICATION AND INFORMATION

The bidder should provide the full company or corporate name, address of the company's headquarters, entity organization (corporation, partnership, proprietorship), state in which the bidder is incorporated or otherwise organized to do business, year in which the bidder first organized to do business and whether the name and form of organization has changed since first organized.

##### b. FINANCIAL STATEMENTS

The bidder should provide financial statements applicable to the firm. If publicly held, the bidder should provide a copy of the corporation's most recent audited financial reports and statements, and the name, address, and telephone number of the fiscally responsible representative of the bidder's financial or banking organization.

If the bidder is not a publicly held corporation, either the reports and statements required of a publicly held corporation, or a description of the organization, including size, longevity, client base, areas of specialization and expertise, and any other pertinent information, should be submitted in such a manner that proposal evaluators may reasonably formulate a determination about the stability and financial strength of the organization. Additionally, a non-publicly held firm should provide a banking reference.

The bidder must disclose any and all judgments, pending or expected litigation, or other real or potential financial reversals, which might materially affect the viability or stability of the organization, or state that no such condition is known to exist.

The State may elect to use a third party to conduct credit checks as part of the corporate overview evaluation.

##### c. CHANGE OF OWNERSHIP

If any change in ownership or control of the company is anticipated during the twelve (12) months following the proposal due date, the bidder should describe the circumstances of such change and indicate when the change will likely occur. Any change of ownership to an awarded vendor(s) will require notification to the State.

**d. OFFICE LOCATION**

The bidder's office location responsible for performance pursuant to an award of a contract with the State of Nebraska should be identified.

**e. RELATIONSHIPS WITH THE STATE**

The bidder should describe any dealings with the State over the previous ten (10) years. If the organization, its predecessor, or any Party named in the bidder's proposal response has contracted with the State, the bidder should identify the contract number(s) and/or any other information available to identify such contract(s). If no such contracts exist, so declare.

**f. BIDDER'S EMPLOYEE RELATIONS TO STATE**

If any Party named in the bidder's proposal response is or was an employee of the State within the past thirty-six (36) months, identify the individual(s) by name, State agency with whom employed, job title or position held with the State, and separation date. If no such relationship exists or has existed, so declare.

If any employee of any agency of the State of Nebraska is employed by the bidder or is a Subcontractor to the bidder, as of the due date for proposal submission, identify all such persons by name, position held with the bidder, and position held with the State (including job title and agency). Describe the responsibilities of such persons within the proposing organization. If, after review of this information by the State, it is determined that a conflict of interest exists or may exist, the bidder may be disqualified from further consideration in this proposal. If no such relationship exists, so declare.

**g. CONTRACT PERFORMANCE**

If the bidder or any proposed Subcontractor has had a contract terminated for default during the past ten (10) years, all such instances must be described as required below. Termination for default is defined as a notice to stop performance delivery due to the bidder's non-performance or poor performance, and the issue was either not litigated due to inaction on the part of the bidder or litigated and such litigation determined the bidder to be in default.

It is mandatory that the bidder submit full details of all termination for default experienced during the past ten (10) years, including the other Party's name, address, and telephone number. The response to this section must present the bidder's position on the matter. The State will evaluate the facts and will score the bidder's proposal accordingly. If no such termination for default has been experienced by the bidder in the past ten (10) years, so declare.

If at any time during the past ten (10) years, the bidder has had a contract terminated for convenience, non-performance, non-allocation of funds, or any other reason, describe fully all circumstances surrounding such termination, including the name and address of the other contracting Party.

**h. SUMMARY OF BIDDER'S CORPORATE EXPERIENCE**

The bidder should provide a summary matrix listing the bidder's previous projects similar to this RFP in size, scope, and complexity. The State will use no more than three (3) narrative project descriptions submitted by the bidder during its evaluation of the proposal.

The bidder should address the following:

Provide narrative descriptions to highlight the similarities between the bidder's experience and this RFP. These descriptions should include:

- a) The time period of the project;
- b) The scheduled and actual completion dates;
- c) The Contractor's responsibilities;
- d) For reference purposes, a customer name (including the name of a contact person, a current telephone number, a facsimile number, and e-mail address); and
- e) Each project description should identify whether the work was performed as the prime Contractor or as a Subcontractor. If a bidder performed as the prime Contractor, the description should provide the originally scheduled completion date and budget, as well as the actual (or currently planned) completion date and actual (or currently planned) budget.

Contractor and Subcontractor(s) experience should be listed separately. Narrative descriptions submitted for Subcontractors should be specifically identified as Subcontractor projects.

If the work was performed as a Subcontractor, the narrative description should identify the same information as requested for the Contractors above. In addition, Subcontractors should identify what share of contract costs, project responsibilities, and time period were performed as a Subcontractor.

**i. SUMMARY OF BIDDER'S PROPOSED PERSONNEL/MANAGEMENT APPROACH**

The bidder should present a detailed description of its proposed approach to the management of the project.

The bidder should identify the specific professionals who will work on the State's project if their company is awarded the contract resulting from this RFP. The names and titles of the team proposed for assignment to the State project should be identified in full, with a description of the team leadership, interface and support functions, and reporting relationships. The primary work assigned to each person should also be identified.

The bidder should provide resumes for all personnel proposed by the bidder to work on the project. The State will consider the resumes as a key indicator of the bidder's understanding of the skill mixes required to carry out the requirements of the RFP in addition to assessing the experience of specific individuals.

Resumes should not be longer than three (3) pages. Resumes should include, at a minimum, academic background and degrees, professional certifications, understanding of the process, and at least three (3) references (name, address, and telephone number) who can attest to the competence and skill level of the individual. Any changes in proposed personnel shall only be implemented after written approval from the State.

**j. SUBCONTRACTORS**

If the bidder intends to Subcontract any part of its performance hereunder, the bidder should provide:

1. name, address, and telephone number of the Subcontractor(s);
2. specific tasks for each Subcontractor(s);
3. percentage of performance hours intended for each Subcontract; and
4. total percentage of Subcontractor(s) performance hours.

**3. TECHNICAL APPROACH**

The technical approach section of the Technical Proposal should consist of the following subsections

**a. Understanding of the project requirements;**

The bidder should provide an overview of proposed solution(s) including but not limited to demonstration of understanding the NETC RFP requirements; the proposed solution(s) whether will meet the RFP specified Project Requirements, Business Requirement, Technical Requirements and Project Planning and Management, will simplify and optimize existing MNCS and able to extend to other identified functional areas; describe phased implementation approach and how the proposed solution will serve future NETC control and monitoring growth and expansion.

**b. Proposed development approach;**

The bidder should provide proposed solution(s) architecture and design including but not limited to methodology of development approach for technology advancement, standards change; adaptability and flexibility of drop or add functionalities and features; roadmap of proposed solution(s) moving forward, and project change management and change order process.

**c. Technical considerations;**

The bidder should provide proposed solution(s) technical considerations including but not limited to methodology of maintaining high availability, quality of services, and traffic and bandwidth management in live, real-time, 24/7/365, 99.99% uptime, broadcast environment; methodology to meet NETC RFP project and technical requirement; system build and validation process; describe project risks and risk management.

**d. Detailed project work plan;**

The bidder should provide a fully executable implementation plan including but not limited to support a smooth transition from existing NMCS (ILC MaxView) to proposed NMCS solution(s) with no business disruption, detailed phased approach for making all RFP listed technical areas fully operational with milestones and timeline for full completion; ongoing technical support during and after the implementation, project planning and management, and system integration.

**e. Deliverables and due dates**

The bidder should provide a detailed deliverables and due dates to meet requirements as set out in this RFP.

## **VIII. COST PROPOSAL REQUIREMENTS**

This section describes the requirements to be addressed by bidders in preparing the State's Cost Sheet. The bidder must use the State's Cost Sheet. The bidder should submit the State's Cost Sheet in accordance with Section I Submission of Proposal.

**THE STATE'S COST SHEET AND ANY OTHER COST DOCUMENT SUBMITTED WITH THE PROPOSAL SHALL NOT BE CONSIDERED CONFIDENTIAL OR PROPRIETARY AND IS CONSIDERED A PUBLIC RECORD IN THE STATE OF NEBRASKA AND WILL BE POSTED TO A PUBLIC WEBSITE.**

### **A. COST SHEET**

This summary shall present the total fixed price to perform all of the requirements of the RFP. The bidder must include details in the State's Cost Sheet supporting any and all costs.

The State reserves the right to review all aspects of cost for reasonableness and to request clarification of any proposal where the cost component shows significant and unsupported deviation from industry standards or in areas where detailed pricing is required.

### **B. PRICES**

Prices quoted shall be net, including transportation and delivery charges fully prepaid by the bidder, F.O.B. destination named in the RFP. No additional charges will be allowed for packing, packages, or partial delivery costs. When an arithmetic error has been made in the extended total, the unit price will govern.

**Form A**  
**Bidder Contact Sheet**  
**Request for Proposal Number 5820 Z1**

Form A should be completed and submitted with each response to this RFP. This is intended to provide the State with information on the bidder's name and address, and the specific person(s) who are responsible for preparation of the bidder's response.

Preparation of Response Contact Information	
Bidder Name:	
Bidder Address:	
Contact Person & Title:	
E-mail Address:	
Telephone Number (Office):	
Telephone Number (Cellular):	
Fax Number:	

Each bidder should also designate a specific contact person who will be responsible for responding to the State if any clarifications of the bidder's response should become necessary. This will also be the person who the State contacts to set up a presentation/demonstration, if required.

Communication with the State Contact Information	
Bidder Name:	
Bidder Address:	
Contact Person & Title:	
E-mail Address:	
Telephone Number (Office):	
Telephone Number (Cellular):	
Fax Number:	

**Form B**  
**Notification of Intent to Attend Pre-Proposal Conference**  
**Request for Proposal Number 5820 Z1**

Bidder Name:	
Bidder Address:	
Contact Person:	
E-mail Address:	
Telephone Number:	
Fax Number:	
Number of Attendees:	

The "Notification of Intent to Attend Pre-Proposal Conference" form should be submitted to the State Purchasing Bureau via e-mail ([as.materielpurchasing@nebraska.gov](mailto:as.materielpurchasing@nebraska.gov)), hand delivered or US Mail by the date shown in the Schedule of Events.

**REQUEST FOR PROPOSAL FOR CONTRACTUAL SERVICES FORM**

By signing this Request for Proposal for Contractual Services form, the bidder guarantees compliance

**BIDDER MUST COMPLETE THE FOLLOWING**

with the procedures stated in this Request for Proposal, and agrees to the terms and conditions unless otherwise indicated in writing and certifies that bidder maintains a drug free work place.

Per Nebraska’s Transparency in Government Procurement Act, Neb. Rev Stat § 73-603 DAS is required to collect statistical information regarding the number of contracts awarded to Nebraska Contractors. This information is for statistical purposes only and will not be considered for contract award purposes.

\_\_\_\_\_ NEBRASKA CONTRACTOR AFFIDAVIT: Bidder hereby attests that bidder is a Nebraska Contractor. “Nebraska Contractor” shall mean any bidder who has maintained a bona fide place of business and at least one employee within this state for at least the six (6) months immediately preceding the posting date of this RFP.

\_\_\_\_\_ I hereby certify that I am a Resident disabled veteran or business located in a designated enterprise zone in accordance with Neb. Rev. Stat. § 73-107 and wish to have preference, if applicable, considered in the award of this contract.

\_\_\_\_\_ I hereby certify that I am a blind person licensed by the Commission for the Blind & Visually Impaired in accordance with Neb. Rev. Stat. §71-8611 and wish to have preference considered in the award of this contract.

**FORM MUST BE SIGNED USING AN INDELIBLE METHOD (NOT ELECTRONICALLY)**

FIRM:	
COMPLETE ADDRESS:	
TELEPHONE NUMBER:	
FAX NUMBER:	
DATE:	
SIGNATURE:	
TYPED NAME & TITLE OF SIGNER:	